

THERMAV™

Trouble Shooting Guide



Navigation Bar

The different category are shown at the side.
So, you can go directly to the index page with
a single click.



Contents

THERMA V™

Trouble Shooting Guide

I . Basic Part

1. Unit Conversion	008
2. Saturation temperature / Saturation pressure table_R410A	009
3. P-H Diagram_R-410A	010
4. P-H Diagram_R32	011

II . Therma V Introduction

1. Nomenclature	014
2. Line Up / Capacity	018
3. Cycle Diagram	019
4. Piping Diagram	022
5. Wiring Diagram	024
6. Exploded View & Part list	032
7. LGMV Checking Point	040
8. Accessory Checking Point	044

III . Self-diagnosis Function

1. Error Code Display	060
2. Error Code Check	065

IV . Function Control

1. Function List	116
2. Function Control Setting	120

V . Checking Method for Key Components

1. Flow Switch	182
2. Water Pump	183
3. Electric Heater	184
4. Remote Controller	185
5. Compressor	186
6. Fan Motor	187

VI . Replacement

1. Replacement procedure for Compressor	190
2. Caution for Assembling Outdoor Panels after Test Run	192
3. Replacement Procedure for INV PCB	193

VII . Test Run Check

1. Checking list of initial installation	196
2. Checklist	198
3. Test run flow chart	220

I. Basic Part

1. Unit Conversion	008
2. Saturation temperature / Saturation pressure table_R410A	009
3. P-H Diagram_R-410A	010
4. P-H Diagram_R32	011

1. Unit Conversion

Power

	kcal/h	Btu/h	(US) RT	(Japan) RT	kW	HP	Nominal HP
kcal/h	1	3.986	0.0003306	0.0003012	0.001162	0.00155	0.0004
Btu/h	0.252	1	0.0000833	0.0000759	0.000293	0.00039	0.0001
(US) RT	3,024	12,000	1	0.91	3.51628	4.69	1.251
(Japan) RT	3,320	13,174.6	1,097	1	3.861	5.149	1.373
kW	860	3,412	0.2843	0.259	1	1.333	0.3555
HP	640	2,559.5	0.213	0.1942	0.75	1	0.2667
Nominal HP	2,400	9,598.1	0.799	0.728	2.81	3.75	1

Pressure

	kgf/cm ²	bar	Pa	atm	lbf/in ² (psi)
kgf/cm ²	1	0.98065	98,066.5	0.9678	14.2233
bar	1.0197	1	100,000	0.9869	14.5028
Pa	0.0000102	0.00001	1	0.00001	0.000145
atm	1.0332	1.01325	101,325	1	14.6959
lbf/in ² (psi)	0.0703	0.06894	6894.7	0.068	1

2. Saturation temperature / Saturation pressure table_R410A

Absolute pressure = Guage pressure(kPa) + 101.325(kPa)

kPa : kgf/cm² x 101.97

R410A					
Temp.	Relative pressure(kPaG)		Relative pressure	Temp.(°C)	
°C	Saturated Liquid	Saturated Gas	kPaG	Saturated Liquid	Saturated Gas
-30	169.62	168.91	170	-30.09	-30.02
-25	229.70	228.81	230	-25.08	-25.01
-20	299.57	298.46	300	-20.06	-19.99
-15	380.23	378.87	380	-15.09	-15.01
-10	472.75	471.09	470	-10.21	-10.12
-5	578.21	576.21	580	-4.98	-4.89
0	697.76	695.38	700	0.04	0.13
5	832.60	829.77	830	4.86	4.96
10	983.94	980.63	980	9.84	9.94
15	1153.09	1149.25	1150	14.88	14.98
20	1341.39	1336.98	1350	20.18	20.29
25	1550.25	1545.26	1550	24.98	25.08
30	1781.19	1775.59	1800	30.36	30.47
35	2035.78	2029.59	2000	34.30	34.42
40	2315.76	2309.03	2300	39.71	39.82
45	2623.00	2615.82	2600	44.62	44.73
50	2959.61	2952.13	2950	49.84	49.95
55	3328.02	3320.49	3400	55.91	56.01
60	3731.18	3724.00	3700	59.61	59.70
65	4173.11	4166.98	4200	65.28	65.34
70	4746.09	4706.31	4700	70.17	70.17

3. P-H Diagram_R410A

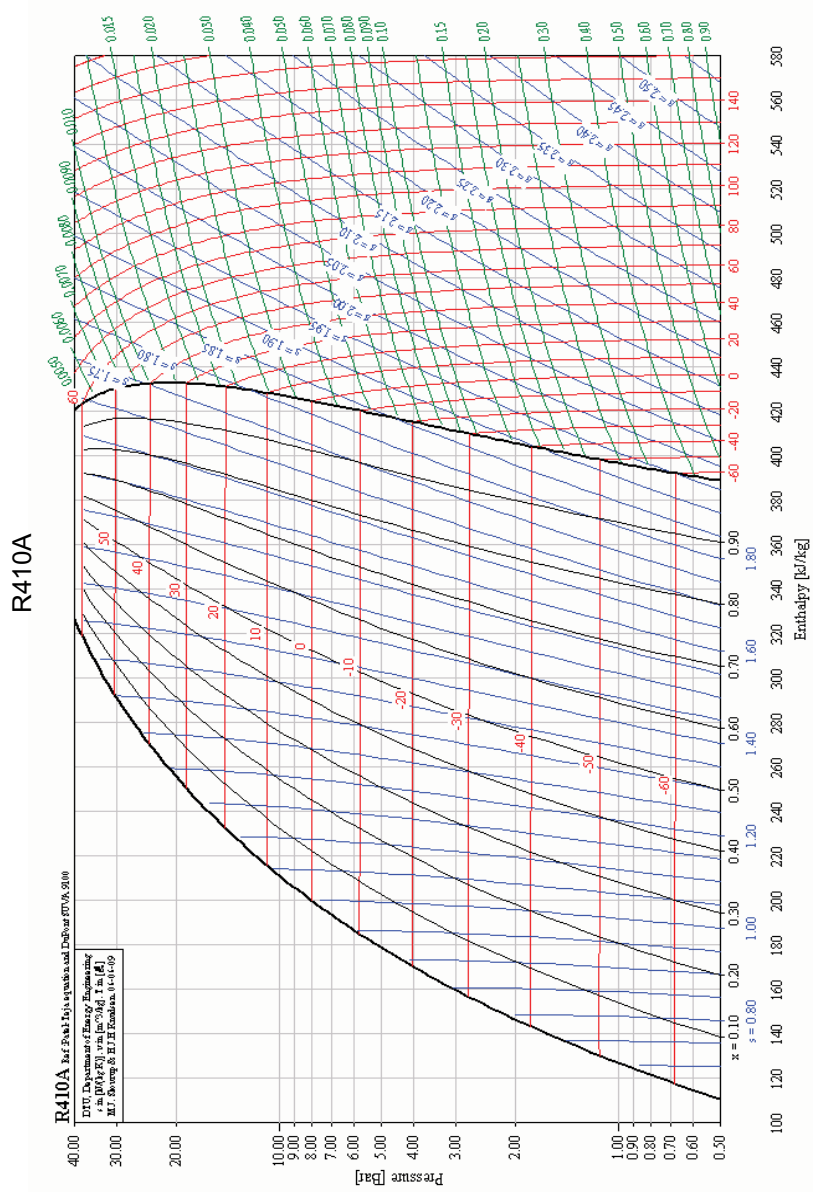

4. P-H Diagram_R32

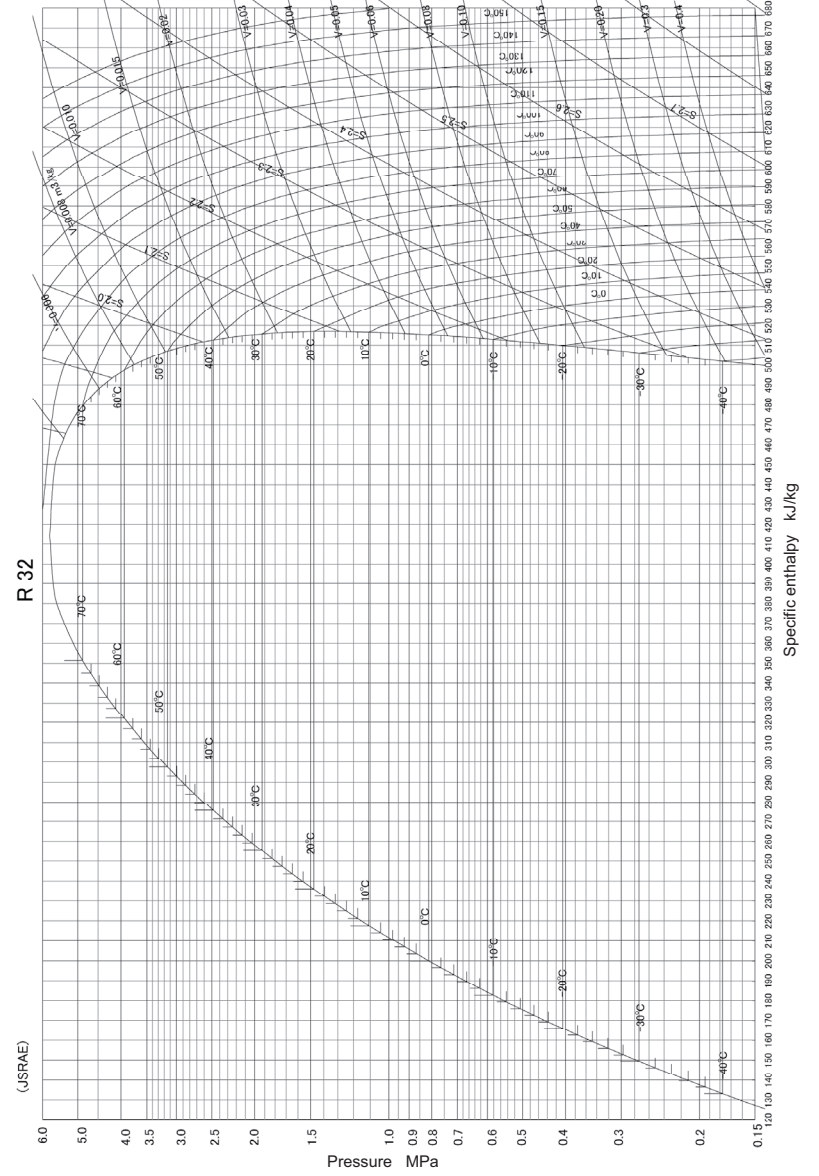

II. Therma V Introduction

1. Nomenclature	014
2. Line Up / Capacity	018
3. Cycle Diagram	019
4. Piping Diagram	022
5. Wiring Diagram	024
6. Exploded View & Part list	032
7. LGMV Checking Point	040
8. Accessory Checking Point	044

1. Nomenclature

1.1 Split Indoor Unit

■ Global Name

Model Name	AH	N	W	16	6	06	A	3
No.	1	2	3	4	5	6	7	8

No.	Signification
1	Air-to-Water Heat Pump for R410A
2	Classification N : Indoor unit of Split type U : Outdoor unit of Split type B : Monobloc type
3	Model Type W : Inverter Heat Pump H : Heat Pump
4	Heating Capacity (kW) Ex) 9kW → '09', 12kW → '12'
5	Heater Electrical ratings 6 : 1Ø, 220-240V, 50 Hz 8 : 3Ø, 380-415V, 50Hz A : 3Ø, 220V, 50Hz
6	Heater Capacity (kW) 06 : 6kW Heater 09 : 9kW Heater
7	Function A : General heating heat pump H : Domestic Hot heating only T : High temperature heating heat pump
8	Serial number 3 Series

■ European Name

Model Name	H	N	16	1	6	T	.	N	B	0
No.	1	2	3	4	5	6*		7	8	9

No.	Signification
1	Air-to-Water Heat Pump for R410A
2	Classification N : Indoor unit of Split type U : Outdoor unit of Split type M : Monobloc type
3	Heating Capacity (kW) Ex) 9kW → '09', 12kW → '12'
4	Heater Electrical ratings 1 : 1Ø, 220-240V, 50 Hz 2 : 3Ø, 220V, 50Hz 3 : 3Ø, 380-415V, 50Hz
5	Nominal Heater Capacity (kW) 00 : None Heater 04 : 4kW heater
6*	Functions T : DHW tank integrated model H : High Temperature heating model (* In case of Hydro Box Low temperature type, here is blank.)
7	Classification N : Indoor unit of Split type U : Outdoor unit of Split type M : Monobloc type
8	Platform (Chassis code) K : K2,K3 Chassis B : DHW tank integrated Platform
9	Serial number

1.2 Split Outdoor Unit

■ Global Name

Model Name	AH	U	W	09	6	A	3
No.	1	2	3	4	5	6	7

No.	Signification
1	Air-to-Water Heat Pump for R410A
2	Classification N : Indoor unit U : Outdoor unit - : Set
3	Model Type W : Inverter Heat Pump H : Heat Pump
4	Heating Capacity (kW) Ex) 5kW : '05', 16kW : '16'
5	Electrical ratings 6 : 1Ø, 220-240V AC 50 Hz 8 : 3Ø, 380-415V AC 50 Hz
6	Function A : General heating heat pump H : Domestic Hot heating only T : High temperature heating heat pump
7	Serial number 3 Series

■ European Name

Model Name	H	U	05	1	.	U	4	3
No.	1	2	3	4		5	6	7

No.	Signification
1	H : Air-to-Water Heat Pump for R410A
2	Classification U : Outdoor unit
3	Heating Capacity (kW) Ex) 5kW : '05', 16kW : '16'
4	Electrical ratings 1 : 1Ø, 220-240V AC 50 Hz 3 : 3Ø, 380-415V AC 50 Hz
5	Classification N : Indoor unit of Split type U : Outdoor unit of Split type M : Monobloc type
6	Platform (Chassis code) 4 : U4 Chassis 3 : U3 Chassis
7	Serial number

1.3 Monobloc

■ Global Name

Model Name	ZH	B	W	12	6	A	0
No.	1	2	3	4	5	6	7

No.	Signification
1	ZH : Air-to-Water Heat Pump for R32
2	Classification B : Monobloc
3	Model Type W : Inverter Heat Pump
4	Heating Capacity (kW) Ex) 5 kW : '05', 16 kW : '16'
5	Electrical ratings 6 : 1 Ø, 220-240 V, 50 Hz 8 : 3 Ø, 380-415 V, 50 Hz
6	Function A : General Heating Heat pump
7	Series

■ European Name

Model Name	H	M	12	1	M	U3	3
No.	1	2	3	4	5	6	7

No.	Signification
1	H : Air-to-Water Heat Pump
2	Classification M : Monobloc type
3	Heating Capacity (kW) Ex) 5 kW : '05', 16 kW : '16'
4	Electrical ratings 1 : 1 Ø, 220-240 V, 50 Hz 3 : 3 Ø, 380-415 V, 50 Hz
5	Leaving Water Combination M : Mid Temperature
6	Platform (Chassis code) U3 : UN3 Chassis U4 : UN4 Chassis
7	Type of refrigerant 2 : R410A 3 : R32

2. Line Up / Capacity

Model Name		Capacity		Power Source (Unit)
Phase	Capacity	Heating(kW)*1	Cooling(kW)*2	
1Ø	5kW	5.5	5.5	220-240 V~ 50 Hz
	7kW	7.0	7.0	
	9kW	9.0	9.0	
	12kW	12.0	12.0	
	14kW	14.0	14.0	
3Ø	16kW	16.0	16.0	380-415 V 3N~ 50 Hz
	12kW	12.0	12.0	
	14kW	14.0	14.0	
	16kW	16.0	16.0	

*1 : Tested under EN 14511 Heating condition
(water out temperature 35 °C at outdoor ambient temperature 7 °C / 6 °C)

*2 : Tested under EN 14511 Cooling condition
(water out temperature 18 °C at outdoor ambient temperature 35 °C / 24 °C)

3. Cycle Diagram

3.1 Split

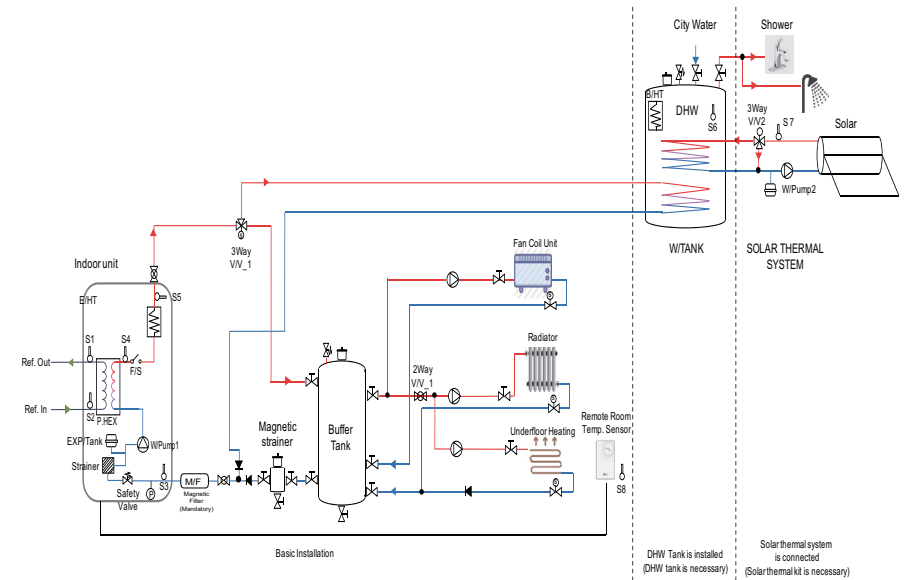

Category	Symbol	Meaning	PCB Connector	Remarks	
Indoor Unit	S1	Refrigerant temperature sensor (Gas side)	CN_PIPE_OUT	- Meaning is expressed based on Cooling mode.	
	S2	Refrigerant temperature sensor (Liquid side)	CN_PIPE_IN		
	S3	Entering Water temperature sensor	CN_TH3		- TH3, TH4, and TH5 are connected at 6 pin type connector CN_TH3.
	S4	Interim Water temperature sensor			
	S5	Leaving Water temperature sensor			
	F/S	Flow Switch	CN_FLOW1		
	E/HT	Electric Heater	CN_E/HEAT(A) CN_E/HEAT(B)	- Heating capacity is divided into two level : partial capacity by E/HEAT(A) and full capacity by E/HEAT(A) + E/HEAT(B). - Operating power(230V AC 50Hz) of E/HEAT(A) and E/HEAT(B) are supplied by external power source via relay connector and ELB.Y12	
	W_PUMP1	Internal Water Pump	CN_MOTOR1	- Water Pump is connected at CN_MOTOR1	
	EXP/TANK	Expansion Tank	(no connector)	- Absorb volume change of heated water,	
	S8	Remote Air temperature sensor	CN_ROOM	- Optional accessory (sold separately) - Model : PQRSTA0	
CTR/PNL	Control Panel (or 'Remote Controller')	CN_REMO	- Pre built-in at indoor unit		
2WAY V/V_1	To control water flow for Fan Coil Unit	CN_2WAY(A)	- 3rd party accessory and Field installation (sold separately) - 2 wire NO or NC type 2way valve is supported		
M/F	Magnetic Filter	(No connector)	- 3rd party accessory and Field installation (sold separately) - It is mandatory to install an additional filter on the heating water circuit.		
Water Heating	W/TANK	DHW Tank	(no connector)	- 3rd party accessory and Field installation (sold separately) - Generating and storing DHW by AWHP or built-in electric heater	
	B/HT	Electric Heater	CN_B/HEAT(A)	- 3rd party accessory and Field installation (usually built-in at W/TANK) - Supplying additional water heating capacity.	
	3WAY V/V_1	- Flow control for water which is leaving from indoor unit. - Flow direction switching between under-floor and water tank	CN_3WAY(A)	- 3rd party accessory and Field installation (sold separately) - SPDT type 3way valve is supported.	
	CITY WATER	Water to be heated by Indoor unit and B/HT of W/TANK	(no connector)	- Field installation	
	SHOWER	Water supplied to end-user	(no connector)	- Field installation	
Solar Heating	S6	W/TANK water temperature sensor	CN_TH4	- TH6 and TH7 are connected at 4 pin type connector CN_TH4. - TH6 is a part of DHW tank kit. (Model:PHLTA) - TH7 is a part of solar thermal kit (Model:PHLLA)	
	S7	Solar-heated water temperature sensor			
	3WAY V/V_2	- Flow control for water which is heated and circulated by SOLAR THERMAL SYSTEM. - Flow direction switching between SOLAR THERMAL SYSTEM and W/TANK	CN_3WAY(B)	- 3rd party accessory and Field installation (sold separately) - SPDT type 3way valve is supported.	
	W_PUMP/2	External Water Pump	CN_W/PUMP(B)	- 3rd party accessory and Field installation (sold separately) - If water pump of SOLAR THERMAL SYSTEM is incapable of circulation, external water pump can be used.	
SOLAR THERMAL SYSTEM	- This system can include following components : Solar panel, Sensors, Thermostats, Interim heat exchanger, Water pump, etc. - To utilized hot water heated by SOLAR THERMAL SYSTEM, end-user must by LG AWHP Solar-Kit.	(no connector)	(no connector)	- 3rd party accessory and Field installation (sold separately)	

3.2 Monobloc

1Ø : 12 kW, 14 kW, 16 kW ; 3Ø : 12 kW, 14 kW, 16 kW

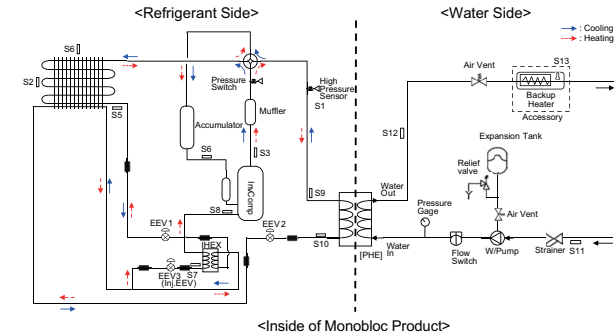

1Ø : 5 kW, 7 kW, 9 kW

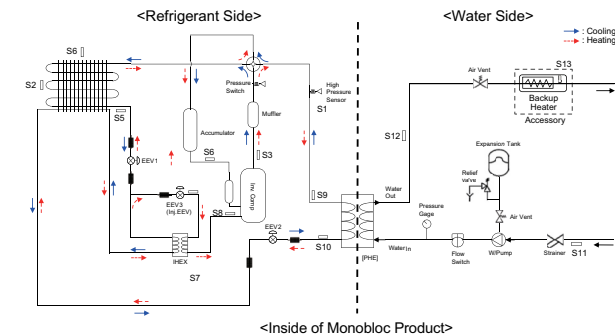

Description

Category	Symbol	Meaning	PCB Connector
Indoor Unit	S1	Meaning pressure sensor	CN_H_PRESS
	S2	Condenser middle temperature sensor	CN_MID
	S3	Compressor-discharge pipe temperature sensor	CN_DISCHA
	S4	Compressor-suction pipe temperature sensor	CN_SUCTION
	S5	Condenser temperature sensor	CN_C_PIPE
	S6	Outdoor air temperature sensor	CN_AIR
	S7	Inlet IHEX temperature sensor	CN_VI_IN
	S8	Outlet IHEX temperature sensor	CN_VI_OUT
	S9	Outlet evaporator	CN_PIPE_OUT
	S10	Inlet evaporator temperature sensor	CN_PIPE_IN
Water Side	S11	Entering water temperature sensor	CN_TH3
	S12	Leaving water temperature sensor	
	S13	Electric backup heater outlet(Accessory kit)	

-S9, S10, S5 : Description is expressed based on Cooling mode.

4. Piping diagram

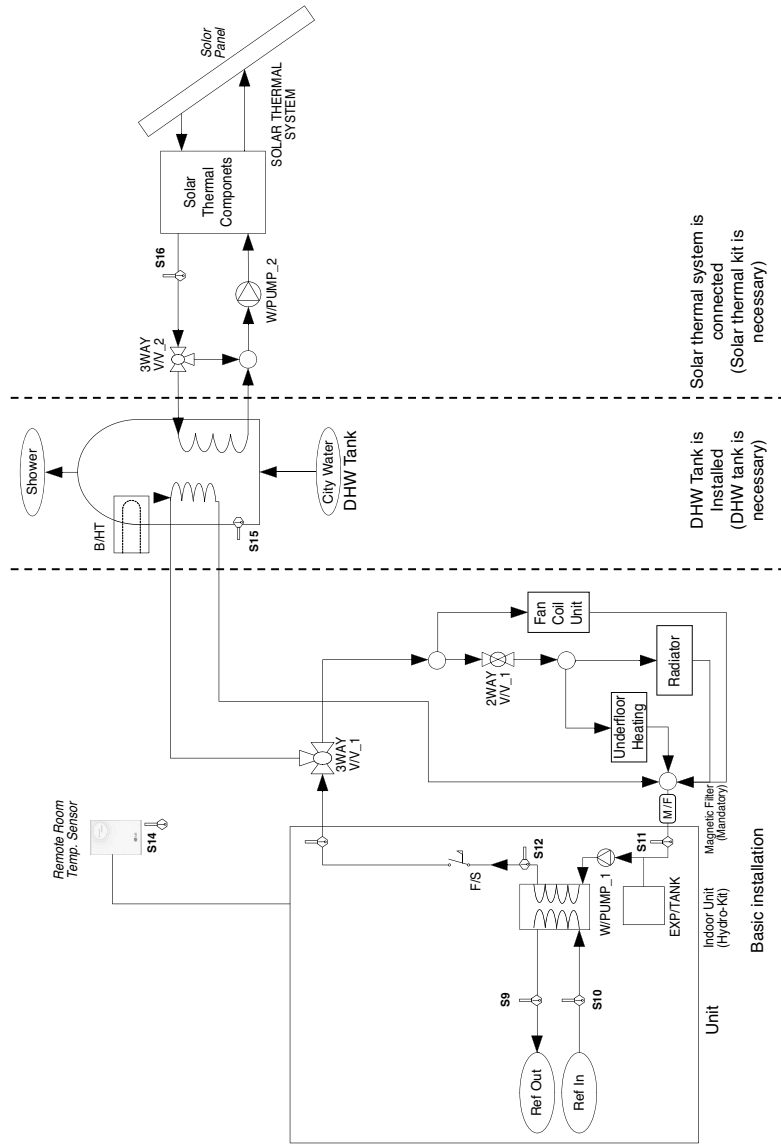

Category	Symbol	Meaning	PCB Connector	Remarks
Unit	S9	Refrigerant temperature sensor (Gas side)	CN_PIPE_OUT	- Meaning is expressed based on Cooling mode.
	S10	Refrigerant temperature sensor (Liquid side)	CN_PIPE_IN	
	S7	Inlet IHEX temperature sensor	CN_VI_IN	
	S8	Outlet IHEX temperature sensor	CN_VI_OUT	
	S3	Compressor-discharge pipe temperature sensor	CN_DISCHA	
	F/S	Flow Switch	CN_FLOW1	
	E/HT	Electric Heater	CN_E/HEAT(A) CN_E/HEAT(B)	<ul style="list-style-type: none"> - Optional accessory (sold separately) - Model : HA**1A E1 - Heating capacity is divided into two level : partial capacity by E/HEAT(A) and full capacity by E/HEAT(A) + E/HEAT(B). - Operating power(220-240 V~ 50 Hz) of E/HEAT(A) and E/HEAT(B) are supplied by external power source via relay connector and ELB.
	W_PUMP1	Internal Water Pump	CN_MOTOR1	- Water Pump is connected at CN_MOTOR1
	EXP/TANK	Expansion Tank (no connector)		- Absorb volume change of heated water,
	S14	Remote Air temperature sensor	CN_ROOM	<ul style="list-style-type: none"> - Optional accessory (sold separately) - Model : PQRSTA0
CTR/PNL	Remote Controller	CN_REMO		
Water Heating	2WAY V/V_1	To control water flow for Fan Coil Unit	CN_2WAY(A)	<ul style="list-style-type: none"> - 3rd party accessory and Field installation (sold separately) - 2 wire NO or NC type 2way valve is supported.
	M / F	Magnetic Filter	(No connector)	<ul style="list-style-type: none"> - 3rd party accessory and Field installation (sold separately) - It is Mandatory to install an additional filter on the heating water circuit.
	W/TANK	DHW Tank	(no connector)	<ul style="list-style-type: none"> - 3rd party accessory and Field installation (sold separately) - Generating and storing DHW by AWHP or built-in electric heater
	B/H/T	Booster heater(in DHW tank)	CN_B/HEAT(A)	<ul style="list-style-type: none"> - 3rd party accessory and Field installation (usually built-in at W/TANK) - Supplying additional water heating capacity.
	3WAY V/V_1	- Flow control for water which is leaving from unit. - Flow direction switching between underfloor and water tank	CN_3WAY(A)	<ul style="list-style-type: none"> - 3rd party accessory and Field installation (sold separately) - SPDT type 3way valve is supported.
	CITY WATER	Water to be heated by Indoor unit and B/H/T of W/TANK	(no connector)	- Field installation
Solar Heating	SHOWER	Water supplied to end-user	(no connector)	- Field installation
	S15	W/TANK water temperature sensor		<ul style="list-style-type: none"> - S15 and TH7 are connected at 4 pin type connector CN_TH4. - S15 is a part of DHW tank kit.(Model : PHLTB) - S16 is a part of solar thermal kit (Model:PHLLA)
	S16	Solar-heated water temperature sensor	CN_TH4	
	3WAY V/V_2	- Flow control for water which is heated and circulated by SOLAR THERMAL SYSTEM. - Flow direction switching between SOLAR THERMAL SYSTEM and W/TANK	CN_3WAY(B)	<ul style="list-style-type: none"> - 3rd party accessory and Field installation (sold separately) - SPDT type 3way valve is supported.
	W_PUMP/2	External Water Pump	CN_W/PUMP(B)	<ul style="list-style-type: none"> - 3rd party accessory and Field installation (sold separately) - If water pump of SOLAR THERMAL SYSTEM is incapable of circulation, external water pump can be used.
SOLAR THERMAL SYSTEM	- This system can include following components : Solar panel, Sensors, Thermostats, Interim heat exchanger, Water pump, etc. - To utilized hot water heated by SOLAR THERMAL SYSTEM, end-user must by LG AWHP Solar-Kit.	(no connector)	<ul style="list-style-type: none"> - 3rd party accessory and Field installation (sold separately) 	

5. Wiring diagram

5.1 Split Indoor Unit 1Ø : 16 kW

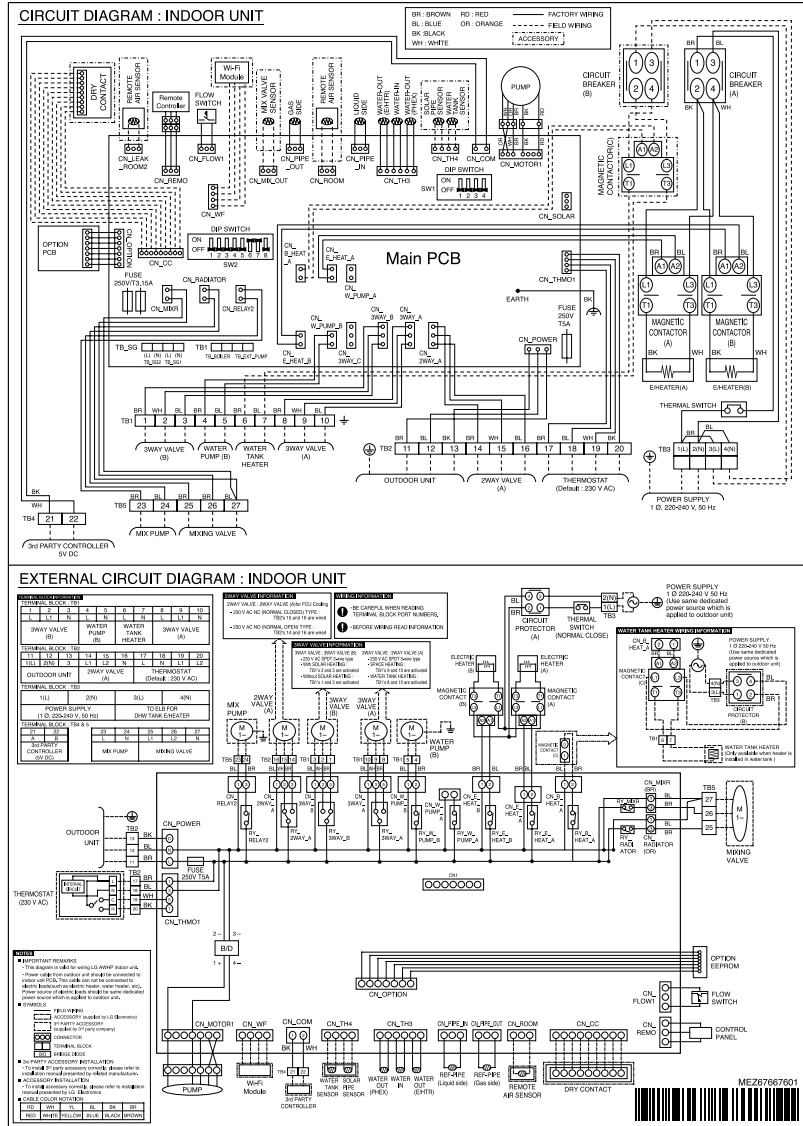

5.2 Split Indoor Unit 3Ø : 16 kW

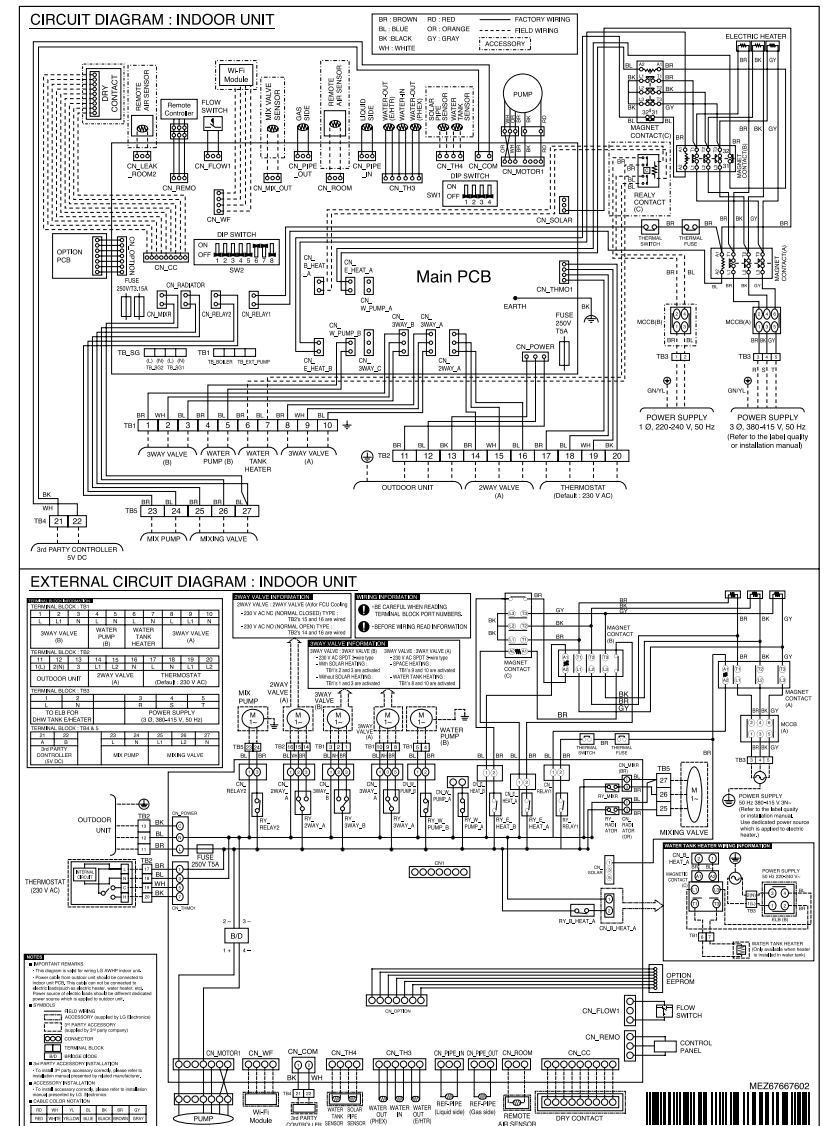

5.3 Split Outdoor Unit : 5 kW, 7 kW, 9 kW

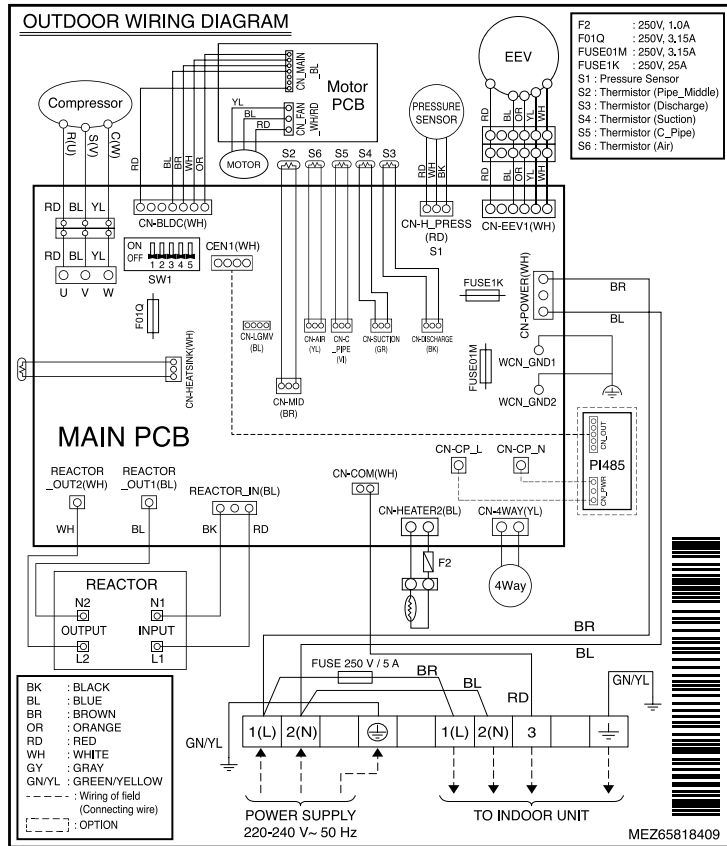

5.4 Split Outdoor Unit 1Ø : 12 kW, 14 kW, 16 kW

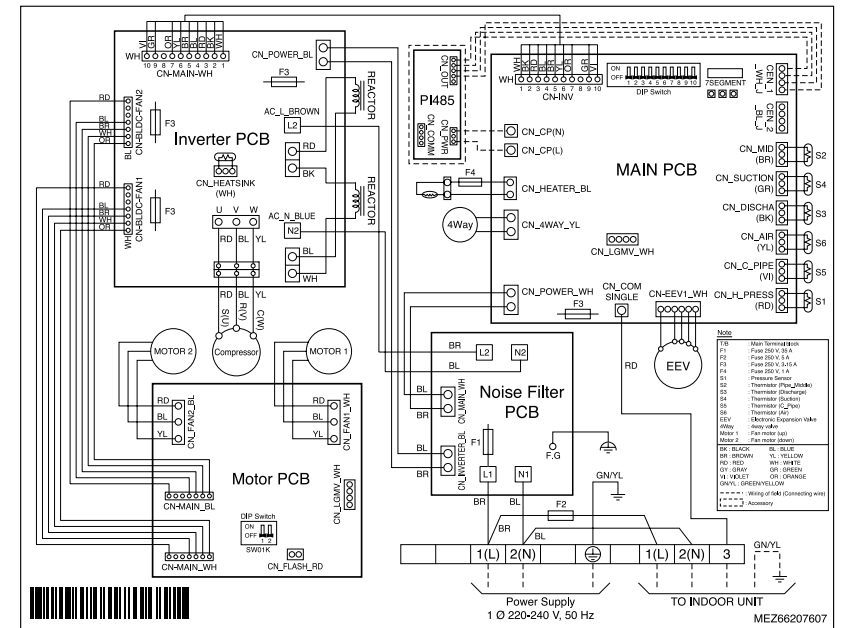

5.5 Split Outdoor Unit 3Ø : 12 kW, 14 kW, 16 kW

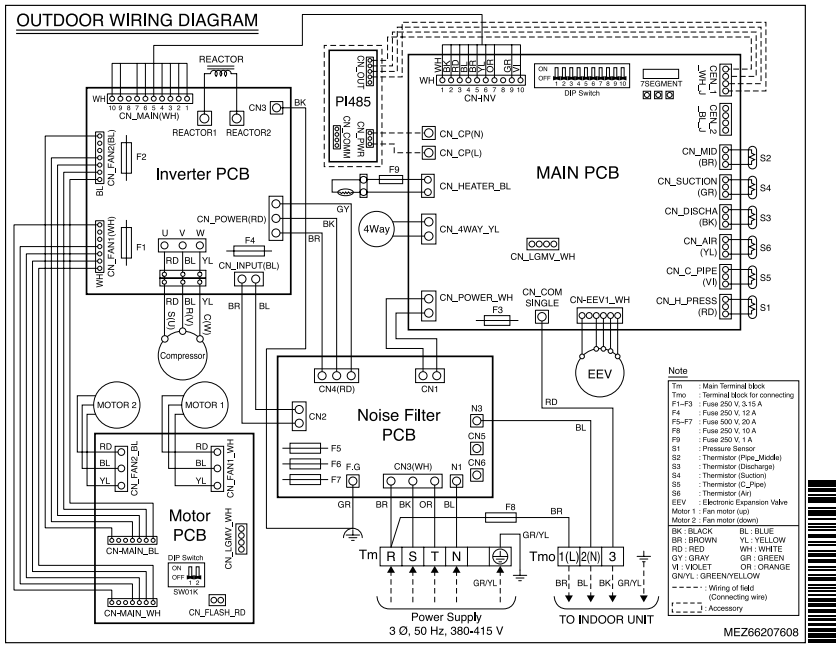

5.6 Monobloc 1Ø : 5 kW, 7 kW, 9 kW

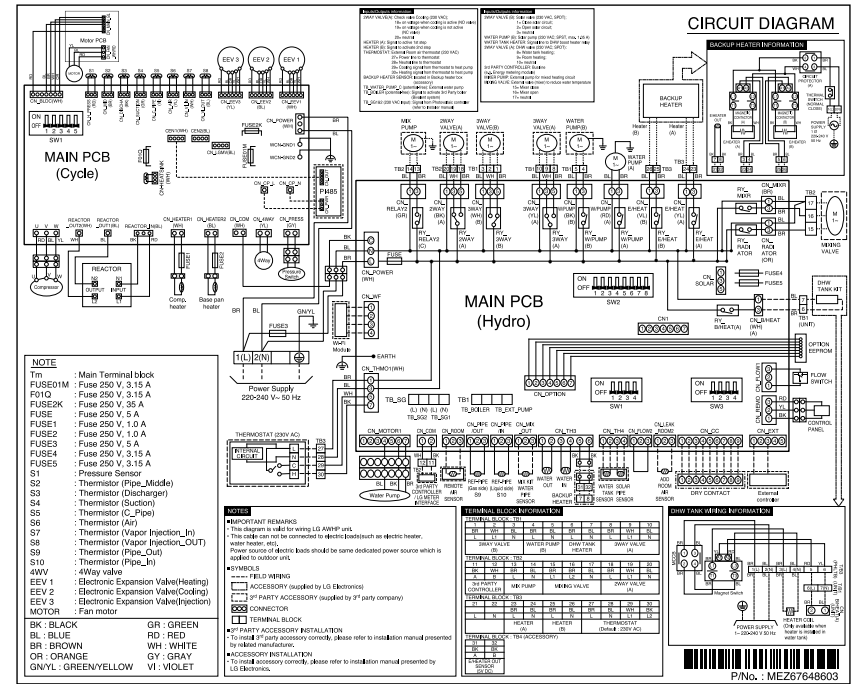

5.7 Monobloc 1Ø : 12 kW, 14 kW, 16 kW

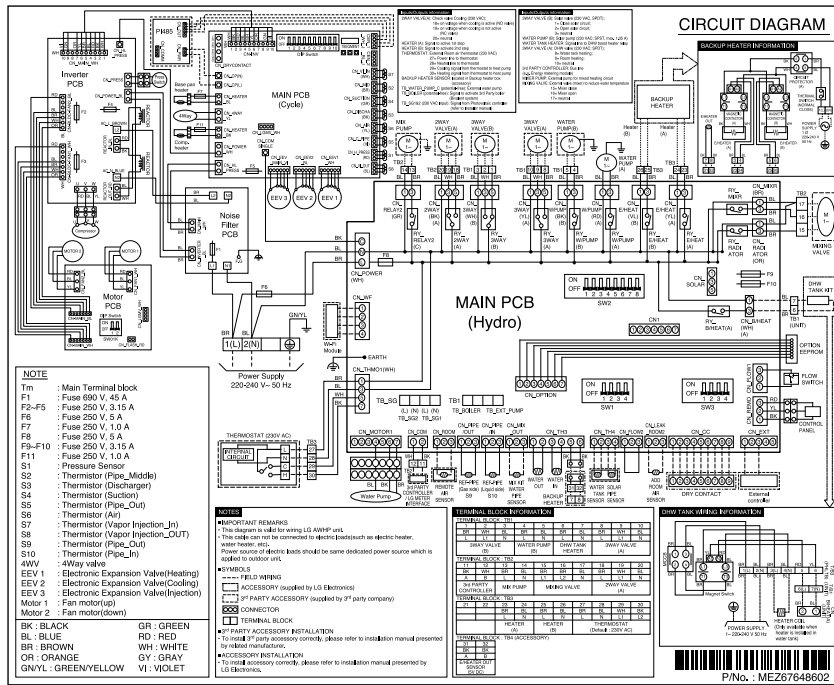

5.8 Monobloc 3Ø : 12 kW, 14 kW, 16 kW

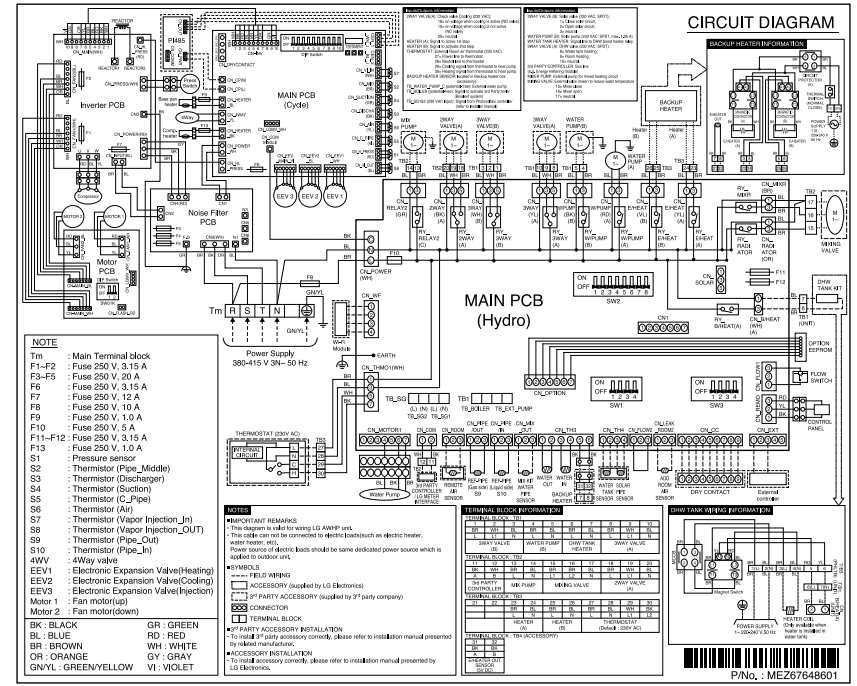

6. Exploded View & Part list

6.1 Split Indoor Unit 1Ø : 16 kW

Model : HN1616.NK3

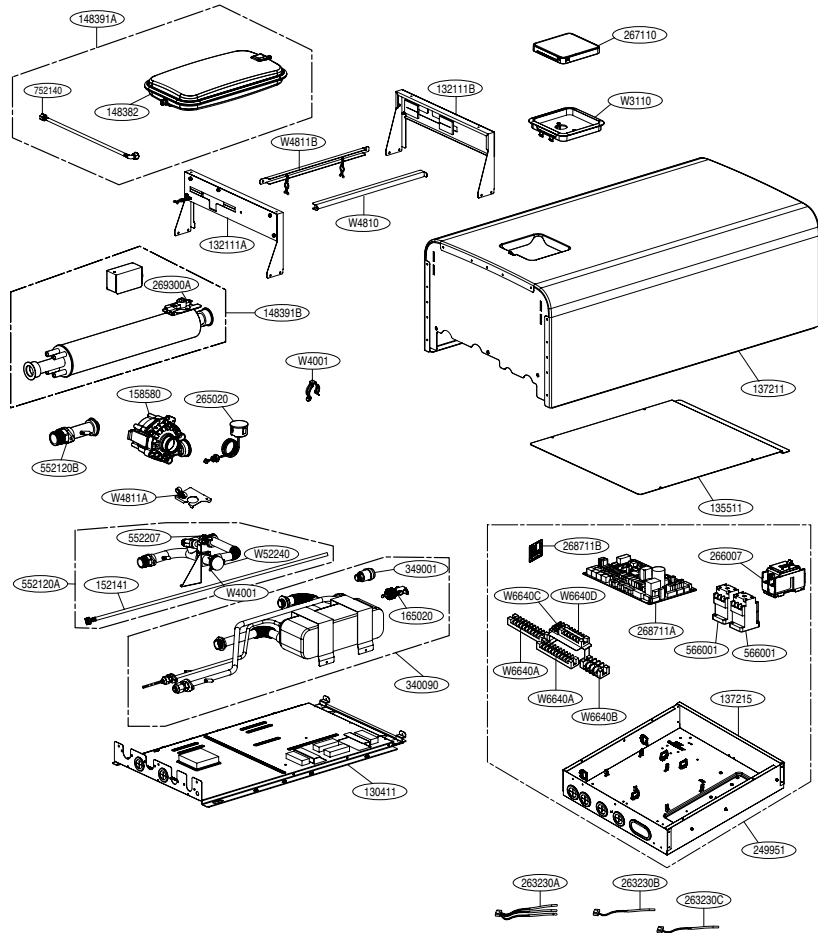

6.2 Split Indoor Unit 3Ø : 16 kW

Model : HN1639.NK3

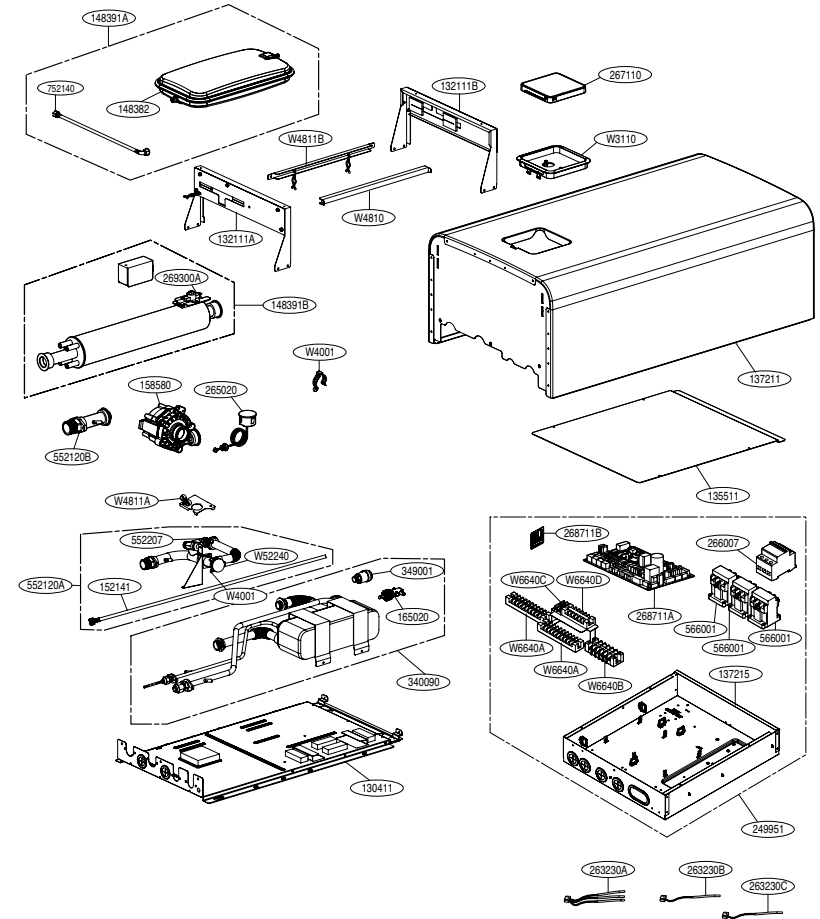

Location No.	Description	Information	Etc.
263230A	Thermistor Assembly,NTC	Water out (E/HTR) / Water in / Water out (PHEX)	CN_TH3
263230B	Thermistor Assembly,NTC	Liquid side	CN_PIPE_IN
263230C	Thermistor Assembly,NTC	Gas side	CN_PIPE_OUT

6.3 Split Outdoor Unit 1Ø : 5 kW, 7 kW, 9 kW

Models : HU123.U33, HU143.U33, HU163.U33

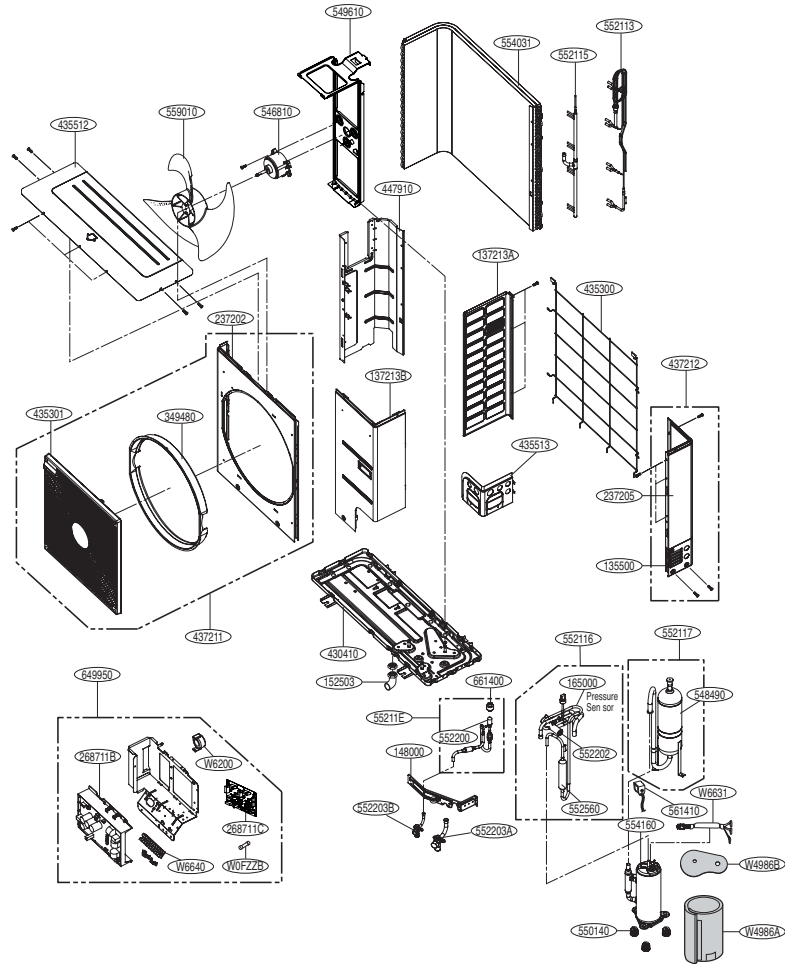

Location No.	Description	Information	Etc.
263230D	Thermistor Assembly,NTC	SUC Temperature	CN_TH4
263230E	Thermistor Assembly,NTC	DIS Temperature	CN_TH5
263230F	Thermistor Assembly,NTC	Outdoor air Temperature	CN_TH7
263230G	Thermistor Assembly,NTC	MID-PIPE Temperature	CN_TH8
263230H	Thermistor Assembly,NTC	Condenser Temperature	CN_TH6

6.4 Split Outdoor Unit 1Ø : 12 kW, 14 kW, 16 kW

Models : HU121.U33, HU141.U33, HU161.U33

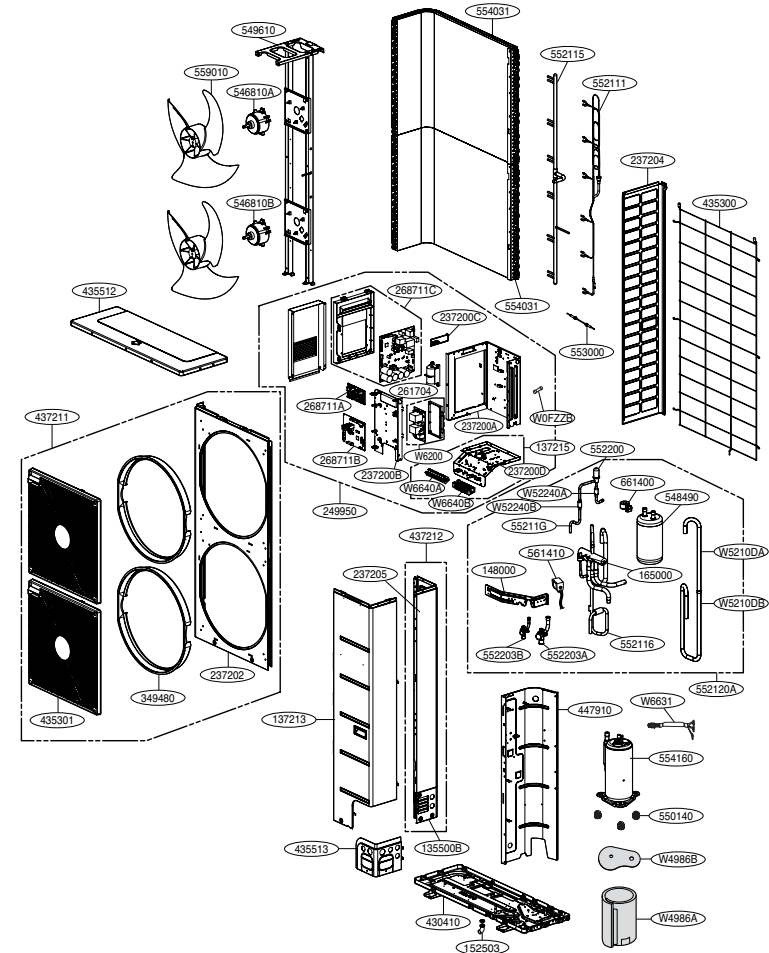

Location No.	Description	Information	Etc.
263230D	Thermistor Assembly,NTC	SUC Temperature	CN_TH4
263230E	Thermistor Assembly,NTC	DIS Temperature	CN_TH5
263230F	Thermistor Assembly,NTC	Outdoor air Temperature	CN_TH7
263230G	Thermistor Assembly,NTC	MID-PIPE Temperature	CN_TH8
263230H	Thermistor Assembly,NTC	Condenser Temperature	CN_TH6

6.5 Split Outdoor Unit 3Ø : 12 kW, 14 kW, 16 kW

Models : HU123.U33, HU143.U33, HU163.U33

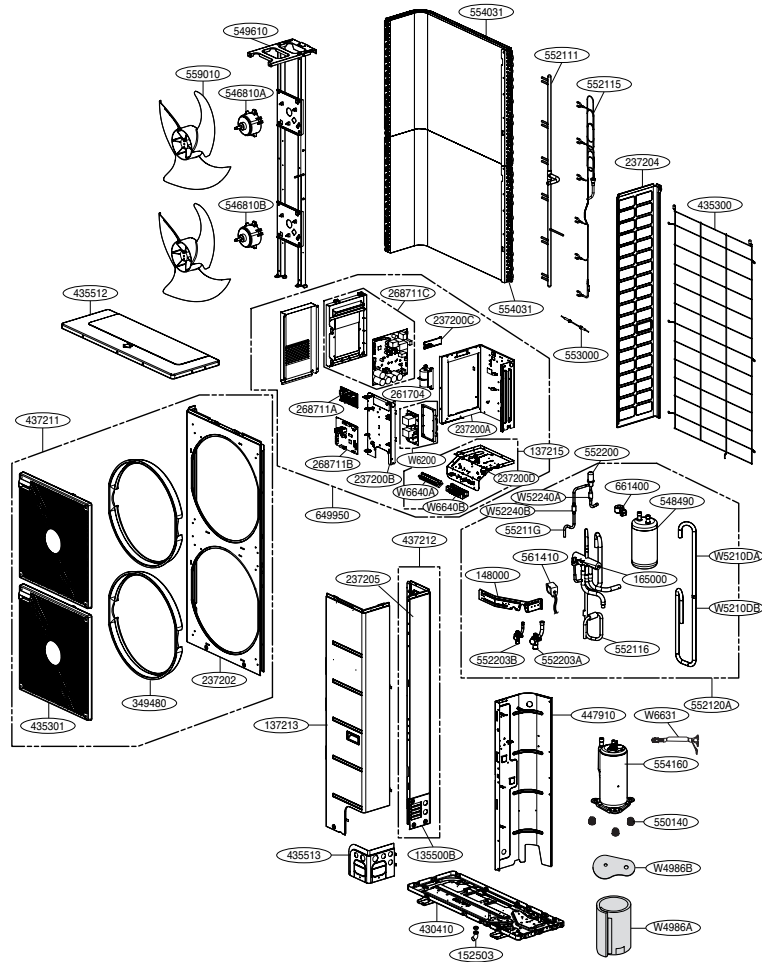

6.6 Monobloc 1Ø : 5 kW, 7 kW, 9 kW

1Ø, 5kW / 7kW / 9kW

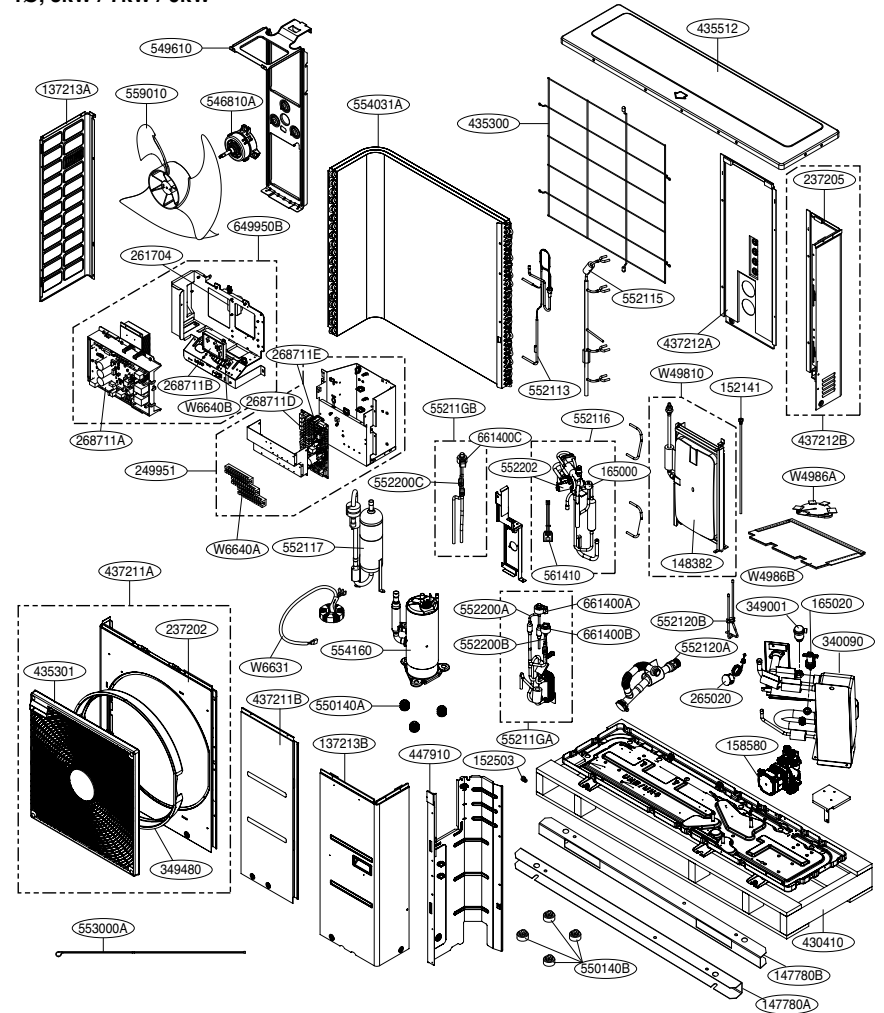

Location No.	Description	Information	Etc.
263230D	Thermistor Assembly,NTC	SUC Temperature	CN_TH4
263230E	Thermistor Assembly,NTC	DIS Temperature	CN_TH5
263230F	Thermistor Assembly,NTC	Outdoor air Temperature	CN_TH7
263230G	Thermistor Assembly,NTC	MID-PIPE Temperature	CN_TH8
263230H	Thermistor Assembly,NTC	Condenser Temperature	CN_TH6

Location No.	Description	Information	Etc.
W50010	Accessory Assembly	Damper / Drain Nipple	Accessory
267110	Remote Controller Assembly	Remote Controller	Accessory

6.7 Monobloc 1Ø : 12 kW, 14 kW, 16 kW
 1Ø, 12kW / 14kW / 16kW

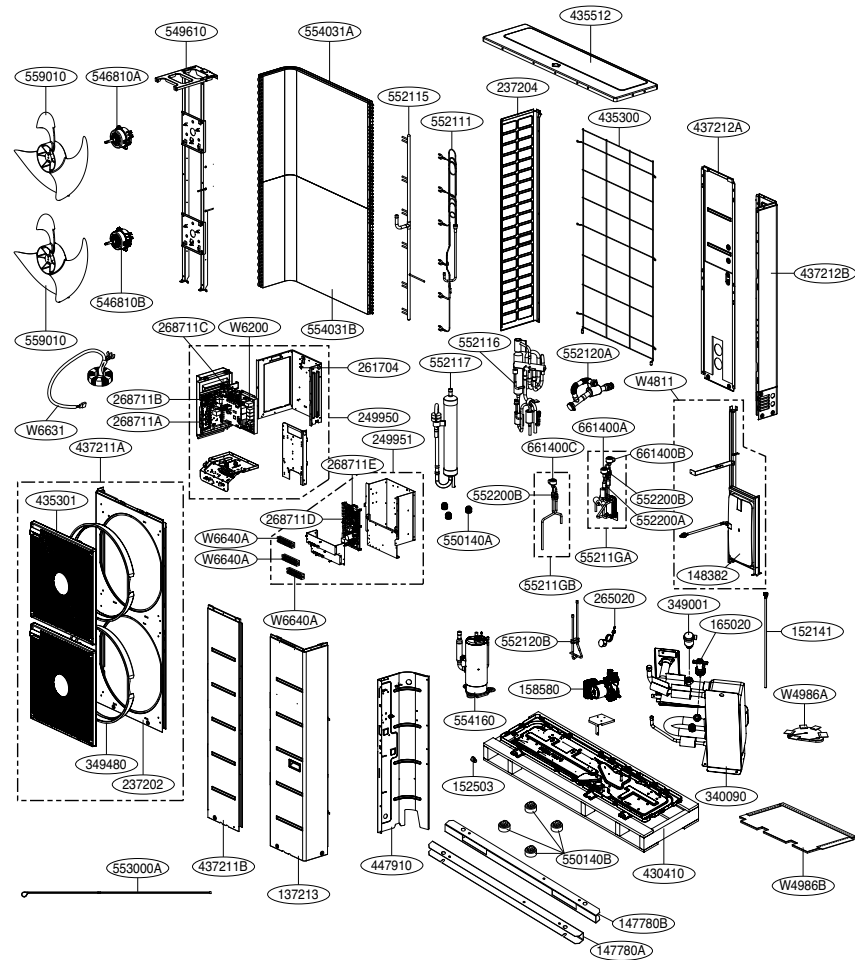

Location No.	Description	Information	Etc.
W50010	Accessory Assembly	Damper / Drain Nipple	Accessory
267110	Remote Controller Assembly	Remote Controller	Accessory

6.8 Monobloc 3Ø : 12 kW, 14 kW, 16 kW
 3Ø, 12kW / 14kW / 16kW

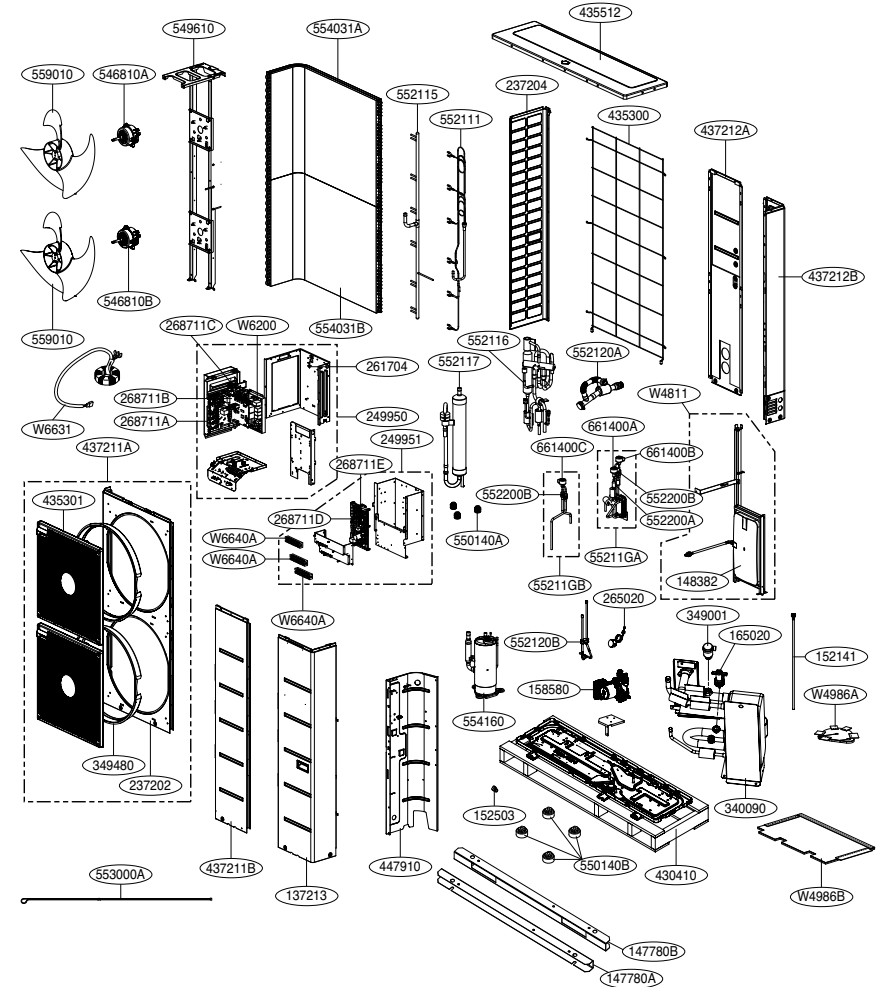

Location No.	Description	Information	Etc.
W50010	Accessory Assembly	Damper / Drain Nipple	Accessory
267110	Remote Controller Assembly	Remote Controller	Accessory

7. LGMV Checking Point

7.1 R410A

Mode	No.	Item	Unit	R410A		Cause & Check Point
				Normal condition	Abnormal condition	
Heating	1	High Pressure	kPa	2300~4000	Above 4100	Overcharging, Heat exchanger fault, Water flowrate shortage, Check that the water inlet temperature is within the operation range. ($\Delta T=5^{\circ}\text{C}$ @Water outlet temp. $35^{\circ}\text{C}/45^{\circ}\text{C}$, $\Delta T=8^{\circ}\text{C}$ @ Water outlet temp. 55°C)
					Below 2200	Ref. shortage, Over water flowrate, Check that the water inlet temperature is within the operation range. ($\Delta T=5^{\circ}\text{C}$ @Water outlet temp. $35^{\circ}\text{C}/45^{\circ}\text{C}$, $\Delta T=8^{\circ}\text{C}$ @Water outlet temp. 55°C)
	2	Low Pressure	kPa	200~1200	Above 1300	Overcharging, Check that the outdoor air temperature is within the operating range.
					Below 200	Ref. shortage, Outdoor Unit Fan lock, Poor airflow in outdoor unit heat-exchanger, Check that the outdoor air temperature is within the operating range.
	3	Indoor Water ΔT (Water out-Water in)	$^{\circ}\text{C}$	-	Below 1°C	Ref. shortage, Over water flowrate, Check that the water inlet temperature is within the operation range. ($\Delta T=5^{\circ}\text{C}$ @Water outlet temp. $35^{\circ}\text{C}/45^{\circ}\text{C}$, $\Delta T=8^{\circ}\text{C}$ @Water outlet temp. 55°C)
	4	Outdoor Ref. Discharge Temp.	$^{\circ}\text{C}$	-	Above 95°C	Ref. Shortage, EEV clogging, Pipe clogging
5	Outdoor Discharge super heat	$^{\circ}\text{C}$	-	Below 5°C	Overcharging, EEV malfunction(Full open)	

7.2 R32

Mode	No.	Item	Unit	R32		Cause & Check Point
				Normal condition	Abnormal condition	
Heating	1	High Pressure	kPa	1000~4200	Above 4200	Overcharging, Outdoor Unit Fan lock, Poor airflow in outdoor unit heat-exchanger, Check that the outdoor air temperature is within the operating range.
					Below 1000	Ref. Leakage or Ref. Shortage, Check that the outdoor air temperature is within the operating range.
	2	Low Pressure	kPa	600~1000	Above 1500	Overcharging, Over Water flowrate, Check that the water inlet temperature is within the operation range. ($\Delta T=5^{\circ}\text{C}$ @Water outlet temp. $35^{\circ}\text{C}/45^{\circ}\text{C}$, $\Delta T=8^{\circ}\text{C}$ @Water outlet temp. 55°C)
					Below 350	Ref. Shortage, Water flowrate shortage, Check that the water inlet temperature is within the operation range. ($\Delta T=5^{\circ}\text{C}$ @Water outlet temp. $35^{\circ}\text{C}/45^{\circ}\text{C}$, $\Delta T=8^{\circ}\text{C}$ @ Water outlet temp. 55°C)
	3	Indoor Ref. ΔT (Pipe in-Pipe out)	$^{\circ}\text{C}$	0~ 10°C	Above 12°C	Ref. Shortage, EEV clogging, Pipe clogging
	4	Indoor Water ΔT (Water out-Water in)	$^{\circ}\text{C}$	-	Below 1°C	Ref. Shortage, Over water flowrate, Check that the water inlet temperature is within the operation range. ($\Delta T=5^{\circ}\text{C}$ @Water outlet temp. $35^{\circ}\text{C}/45^{\circ}\text{C}$, $\Delta T=8^{\circ}\text{C}$ @Water outlet temp. 55°C)
5	Outdoor Ref. Discharge Temp.	$^{\circ}\text{C}$	-	Above 110°C	Ref. Shortage, EEV clogging, Pipe clogging	
6	Outdoor Discharge super heat	$^{\circ}\text{C}$	-	Below 5°C	Overcharging, EEV malfunction(Full open)	

Accessories supported by LG Electronics

Item	Purpose	Model
DHW Tank Install Kit	To operate with DHW tank	PHLTA : Split 1 Ø PHLTB : Monobloc PHLTC : Split 3 Ø
Thermistor for DHW Tank	To control hot water temperature of DHW tank	PHRSTA0
Remote Temperature Sensor	To control by air temperature	PQRSTA0
Dry Contact	To receive on & off external signal	PDRYCB500
	Dry Contact For Thermostat	PDRYCB300
Solar thermal Kit	To operate with solar heating system	PHLLA(Limit temperature : 96 °C)
Meter Interface	To measure production / consumption power	PENKTH000
Central Controller	Multiple installed products into one central control	
Backup heater	To supplement insufficient capacity	HA031M E1: 1Ø 3 kW HA061M E1: 1Ø 6 kW HA063 E1 : 3 Ø 6 kW (Launch : `19.04) (Only Monobloc)
Wi-Fi Modem	To enable remote system operation from smartphone	PWFMD200
Thermistor for 2nd Circuit	To interlock with 2nd circuit operation and control temperature of main zone.	PRSTAT5K10 (Launch : `19.03)
Extension wire	To connect remote controller with Indoor PCB for communication	PZCWRC1
Drain pan	To prevent drain water drop	PHDPB(Only Split)

Accessories supported by 3rd party Companies

Item	Purpose	Specification
Solar Heating System	To generate auxiliary heating energy for water tank	• Solar collector • 3way valve(B)
Mix Kit	To use 2nd Circuit	• Mixing valve • Mix pump
3rd Party Boiler	To use auxiliary boiler.	
3rd Party Controller	To connect external controller using modbus protocol	
Thermostat	To control by air temperature	Heating-Only type (230 V AC) Cooling/Heating type (230 V AC with Mode selection switch)
3way valve and actuator	(A) : To control water flow for hot water heating or floor heating (B) : To control close/open mode of solar circuit To control 3rd party boiler on/off mode	3 wire, SPDT (Single Pole Double Throw) type, 230 V AC
2way valve and actuator	To control water flow for Fan Coil Unit To serve as 3way valve when installing backup heater(Only monobloc)	2 wire, SPST(Single Pole Sing Throw) type, 230 V AC
External Pump	To retain sufficient capacity using additional pump	
Smart Grid	To control operation mode depending on input signal from provider	

8. Accessory Checking Point

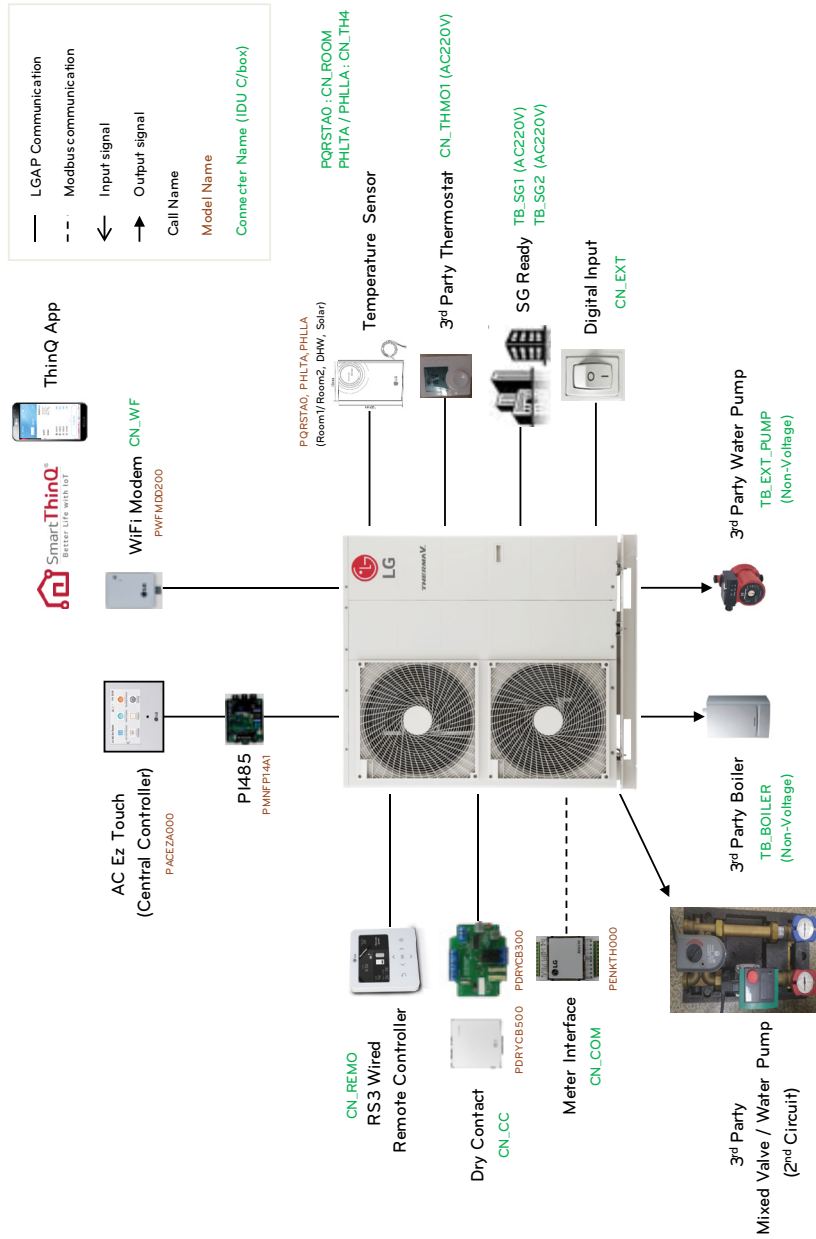

Refer to Installation guide to check the wiring condition of accessory.

How to Wire 2nd Circuit

Follow below procedures Step 1 ~ Step 2.

Step 1. Uncover front cover of the unit.

Step 2. Find terminal block and connect wire as below

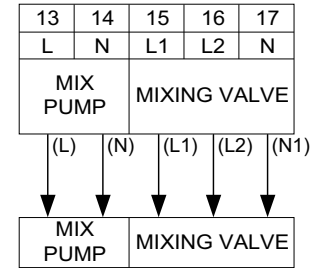

(L) : Live signal from PCB to mix pump

(N) : Neutral signal from PCB to mix pump

(L1) : Live signal (for Normal *Closed type) from PCB to mixing valve

(L2) : Live signal (for Normal Open type) from PCB to mixing valve

(N1) : Neutral signal from PCB to mixing valve

*Closed type = NOT mixed

How to Wire Temperature sensor for 2nd Circuit

Temperature sensor is used to interlock with 2nd circuit operation and control temperature of main zone. (Model name : PRSTAT5K10)

Insert the sensor to 'CN_MIX_OUT' (Brown) of the main PCB as shown below.

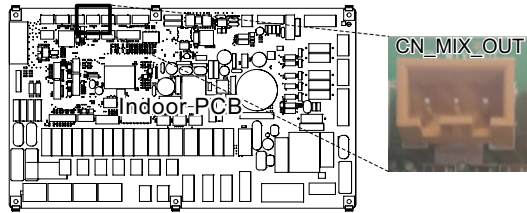

- For detailed installation instructions, refer to the following installation sense.

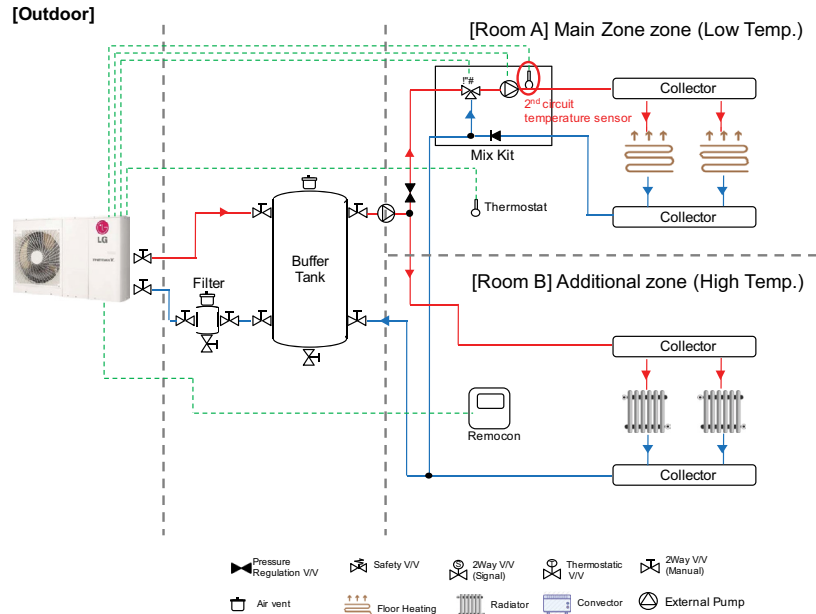

How to install 3rd party boiler

Follow below procedures step 1 ~ step 3.

Step 1. Check if the power of the unit is turned off.

Step 2. Disassemble front panels and Distinguish terminal block in Indoor PCB.

Step 3. Connect Single Cable to terminal block (TB_BOILER) fully.

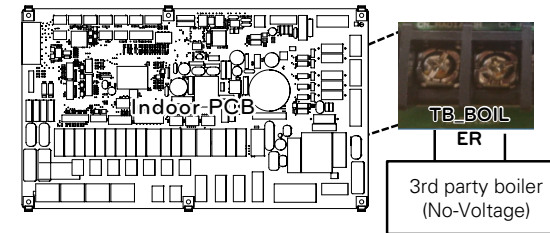

- For detailed installation instructions, refer to the following installation sense.

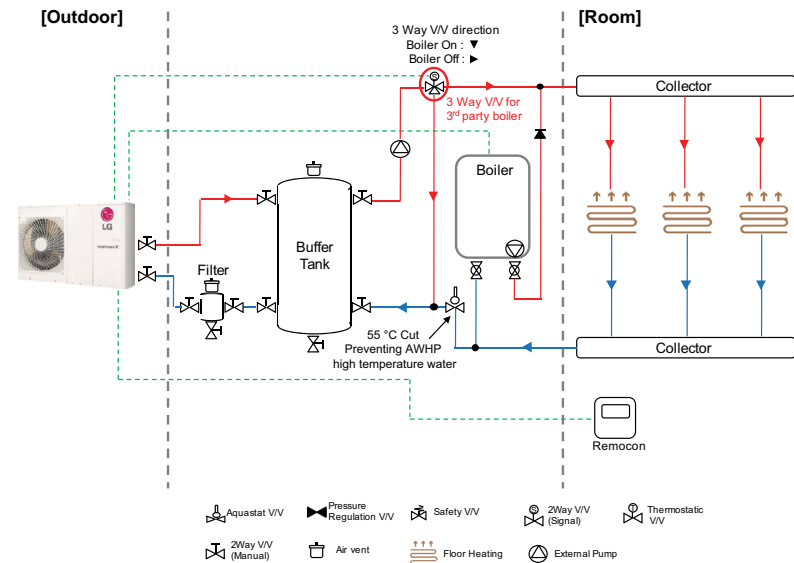

How to install 3rd party controller

Follow below procedures step 1 ~ step 4.

Step 1. Check if the power of the unit is turned off.

Step 2. Disassemble front panels and distinguish control box(Indoor) of the unit.

Step 3. Check if the harness(White) is inserted fully to the indoor unit PCB (CN_COM).

Step 4. Connect the 3rd party controller to terminal block 2(11/12) completely. (including Meter interface module)

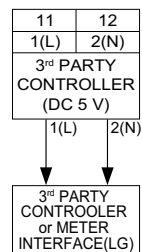
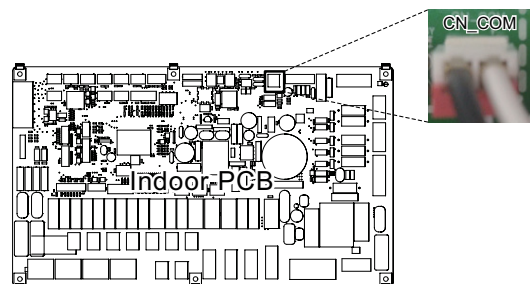

How to install Meter Interface

Follow below procedures step 1 ~ step 4.

Step 1. Check if the power of the unit is turned off.

Step 2. Disassemble front panels and Distinguish control box(Indoor) of the unit.

Step 3. Check if the harness(White) is inserted fully to the indoor unit PCB (CN_COM).

Step 4. Connect the external pump to terminal block 2(11/12).

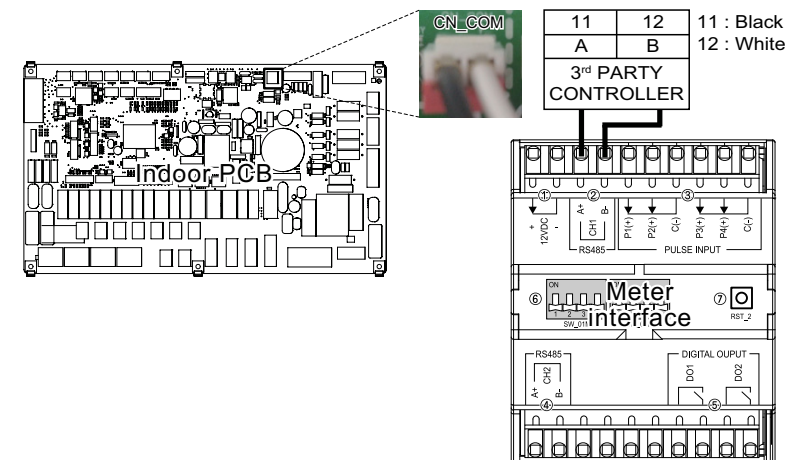

How to install DHW tank kit

Follow below procedures step 1 ~ step 4.

Step 1. Uncover DHW tank kit and locate it on the wall.

Step 2. Connect Harness(Violet) of Main PCB assembly(TB1(6/7)) to 'CN_B_Heat_A' of the Main PCB like following fig. 1.

Step 3. Insert DHW tank sensor to 'CN_TH4' (Red) of the Main PCB refer as below.

Step 4. Connect power supply to the DHW tank kit as shown fig. 1.

※ The sensor should be mounted correctly to the sensor hole of DHW water tank like below fig. 2.

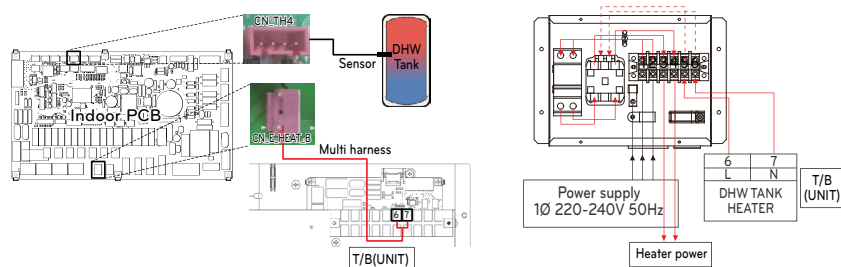

Fig. 1

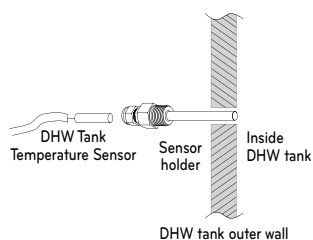

Fig. 2

How to Install Solar Thermal Kit

Follow below procedures step 1 ~ step 4.

Step 1. Install tube connector(it is necessary to reduce or extend diameter of pipe.) the pipe and solar thermal kit.

Step 2. Check if the power of the unit is turned off.

Step 3. Disassemble front panels and distinguish control box(Indoor) of the unit.

Step 4. Insert harness into PCB(CN_TH4) fully and fix the thermal sensor into tube connector as shown below.

※ If the DHW tank sensor is connected, disconnect the sensor from PCB first.

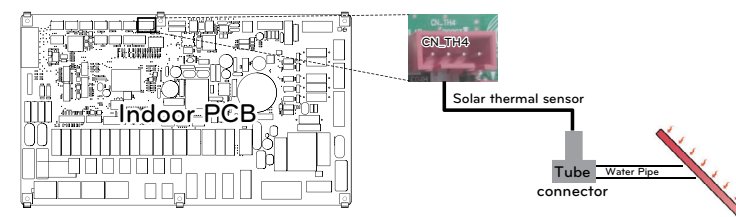

How to install dry contact

Step 1. Check if the power of the unit is turned off.

Step 2. Disassemble front panels and distinguish terminal block in Indoor PCB.

Step 3. Connect cable to the unit PCB(CN_CC) fully.

Step 4. Then, Insert harness to the dry contact PCB(CN_INDOOR) firmly as shown below.

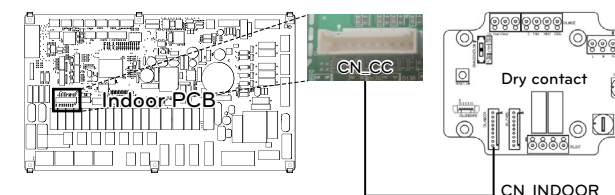

How to Install Remote Temperature Sensor

Follow below procedures step 1 ~ step 5.

- Step 1.** Decide where the remote temperature sensor is installed. Then, Determine the location and height of the fixing screws in fig. 1 (Interval between the screws : 60mm)
- Step 2.** Check if the power of the unit is turned off.
- Step 3.** Disassemble front panels and distinguish control box(Indoor) of the unit.
- Step 4.** Insert temperature sensor into PCB(CN_ROOM) and fix the sensor firmly in fig. 2.
- Step 5.** The Connection wire does not matter if you change the color of the wire because of nonpolar.

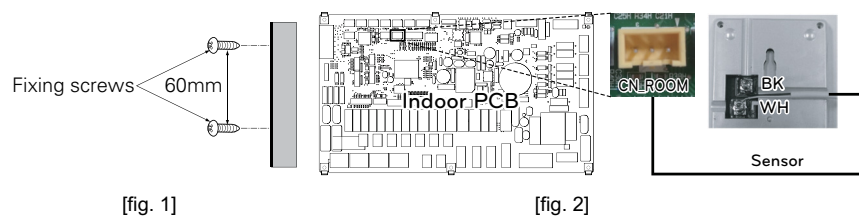

- Step 6.** Integrate the remote temperature sensor with the screws as the order of arrows.

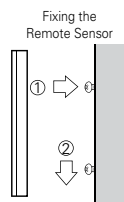

How to install solar pump

Follow below procedures step 1 ~ step 4.

- Step 1.** Check if the power of the unit is turned off.
- Step 2.** Disassemble front panels and distinguish control box(Indoor) of the unit.
- Step 3.** Check if the harness(Black) is inserted fully to the indoor unit PCB (CN_W_PUMP_B).
- Step 4.** Connect the external pump to terminal block 1(4/5).

* It is possible to unuse solar pump depending on installation environment.

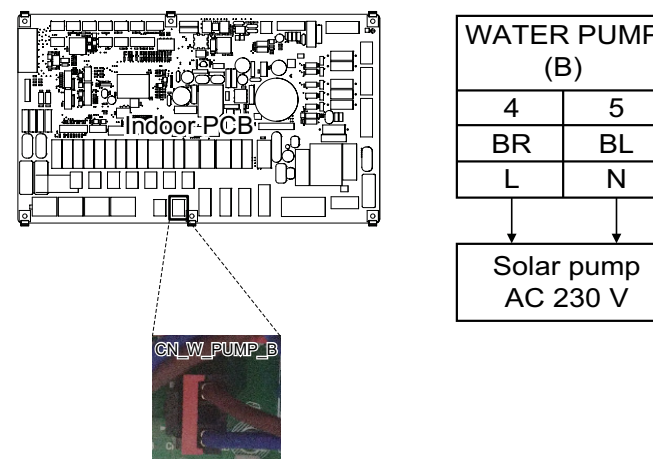

How to install external pump

Follow below procedures step 1 ~ step 3.

Step 1. Check if the power of the unit is turned off.

Step 2. Disassemble front panels and distinguish terminal block in Indoor PCB.

Step 3. Connect Signal cable to terminal block (TB_W_PUMP_C) fully.

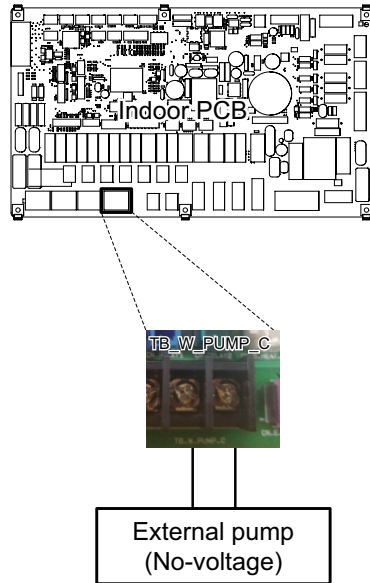

How to install Wi-fi Modem

Follow below procedures step 1 ~ step 5.

Step 1. Check if the power of the unit is turned off.

Step 2. Disassemble front panels and distinguish terminal box(Indoor) of the unit.

Step 3. Connect the USB cable to the indoor unit PCB (CN_WF ; Blue) until it clicks into place.

Step 4. Connect the Wi-Fi modem to the USB cable fully.

Step 5. Refer to the image below to install the Wi-Fi modem in the marked position.

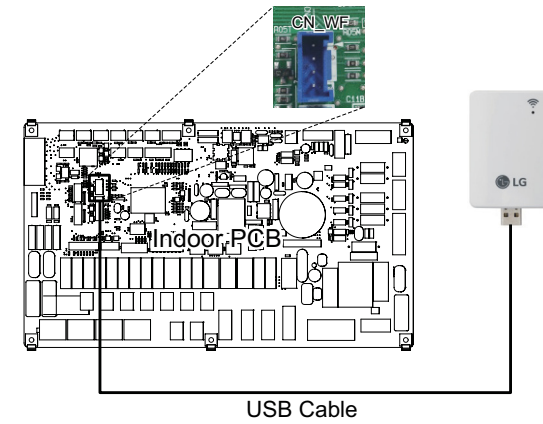

How to install smart grid

Follow below procedures step 1 ~ step 3.

Step 1. Check if the power of the unit is turned off.

Step 2. Disassemble front panels and distinguish terminal block in Indoor PCB.

Step 3. Connect Power cable to terminal block in PCB (TB_SG2, TB_SG1) fully as shown below.

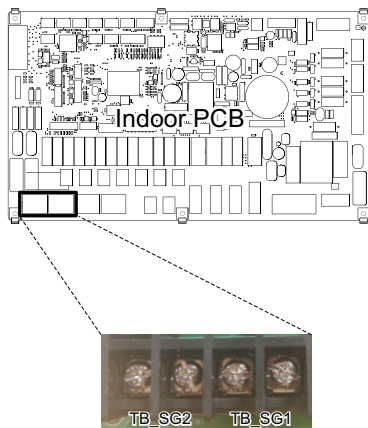

Heating and DHW Operation depend on input signal (SG1 / SG2)

Status display	Input Signal		Command	Cost (Electric)	Operation	
	SG1	SG2			Heating	Domestic How Water
SGN	Open	Open	Normal Operation	Normal Price	Maintain operation status	Maintain operation status
SG1	Close	Open	Operation Off (Utility lock)	High Price	Forced internal operation off	Forced internal operation off
SG2	Open	Close	Operation On Recommend	Low Price	Target temperature change automatically depend on SG Mode value in installer setting - Step 0 : maintain target temperature - Step 1 : increase 2 °C from target temperature - Step 2 : increase 5 °C from target temperature	Target temperature change automatically depend on SG Mode value in install setting - Step 0 : increase 5 °C from target temperature - Step 1 : increase 5 °C from target temperature - Step 2 : increase 7 °C from target temperature
SG3	Close	Close	Operation On Command	Very Low Price	Maintain operation status	Target temperature change automatically to 80 °C

[Status display]

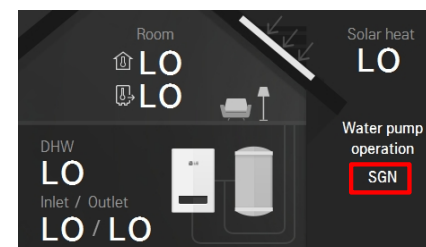

THERMA V™

III. Self-diagnosis Function

- | | |
|-----------------------|-----|
| 1. Error Code Display | 060 |
| 2. Error Code Check | 065 |

How to install External Controller (Setting up Programmable digital input operation)

Follow below procedures step 1 ~ step 4.

Step 1. Check if the power of the unit is turned off.

Step 2. Disassemble front panels and distinguish control box(Indoor) of the unit

Step 3. Connect the external controller to PCB(CN_EXT) completely.

Step 4. Connect the cable and field installation part.

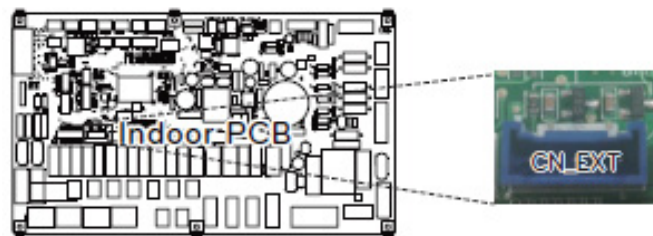

Adapter Cable

1. Error Code Display

Concept of 'Classified Trouble'

• Definition of terms

- Trouble : a problem which can stop system operation, and can be resumed temporarily under limited operation without certificated professional's assist.
- Error : a problem which can stop system operation, and can be resumed ONLY after certificated professional's check.
- Emergency mode : temporary heating operation while system met Trouble

• Objective of introducing 'Trouble'

- Not like airconditioning product, Air-to-Water heat pump is generally operating in whole winter season without any system stopping.
- If system found some problem, which is not critical to system operating for yielding heating energy, the system can temporarily continue operating in emergency mode with enduser's decision.

• Slight Trouble(S-Trouble)

A trouble is occurred with temperature sensor of indoor unit. (sensing fail)
Emergency operation(heating) is possible with heat pump and electric heater.

• Heavy Trouble(H-Trouble)

A trouble is occurred with cycle and system can not be operated
Emergency operation(heating) is possible with electric heater ONLY.

• Other Trouble(O-Trouble)

A trouble is occurred with optional function. (e.g. DHW tank sensor, Solar thermal sensor)
Emergency operation(heating) is possible with heat pump and electric heater.
In case of CH13, Heat pump operation does not stop.

• Error

A serious fail was found and system can not be used before repair it.

• Emergency operation is not automatically restarted after main electricity power is reset.

- In normal condition, the product operating information is restored and automatically restarted after main electricity power is reset.
- But in emergency operation, automatic re-start is prohibited to protect the product.
- Therefore, user must restart the product after power reset when emergency operation has been running.

Error Code List

Error Code	Level	Description	Cause of Error
1	S-Trouble	Problem in remote air sensor	Remote air temperature sensor of indoor unit is open or short.
2	H-Trouble	Problem in refrigerant inlet(liquid) side sensor	Refrigerant inlet pipe temperature sensor of indoor unit is open or short.
3	Error	Bad communication between remote controller and indoor unit	It is failed to receive wired remote controller signal in indoor unit PCB.
5	H-Trouble	Bad communication between outdoor unit and indoor unit	It is failed to receive the signal from ODU.
6	H-Trouble	Problem in refrigerant outlet(gas) side sensor	Refrigerant outlet pipe temperature sensor of indoor unit is open or short.
8	O-Trouble	Problem in water tank sensor	Domestic hot water tank temperature sensor of indoor unit is open or short.
9	Error	PCB Program (EEPROM) Fault	EEPROM is self-defective or fixed incorrectly on option PCB by poor soldering.
10	Error	BLDC Water pump Lock	Water pump connector is disconnected./Water Pump is self-defective.
13	O-Trouble	Problem in solar pipe sensor	Solar pipe temperature sensor of indoor unit is open or short.
14	Error	Problem in flow switch	If water pump is turned on(off) , flow switch is open(short) for 15 seconds.
15	Error	Water pipe strange overheat	Leaving water temperature is above 72 °C.(heater integrated model : Split) Leaving water temperature is above 67 °C.(heater option model : Monobloc)
16	Error	Problems in sensors	An error cord 17,18,19 error has occurred at the same time.
17	S-Trouble	Problem in Water-inlet sensor	Water inlet pipe temperature sensor of indoor unit is open or short.
18	S-Trouble	Problem in Water-outlet sensor	Water outlet pipe temperature sensor of indoor unit is open or short.
19	S-Trouble	Problem in electric backup heater outlet sensor	Electric backup heater outlet temperature sensor of indoor unit is open or short.
20	Error	Damaged thermal fuse	Fuse of electric heater is blown due to overheat.

1.1 1Ø : 5 kW, 7 kW, 9 kW

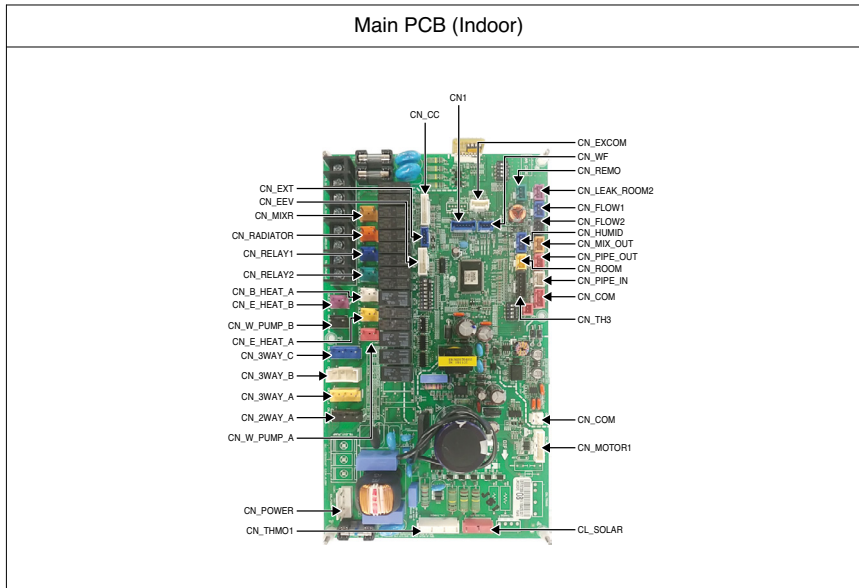
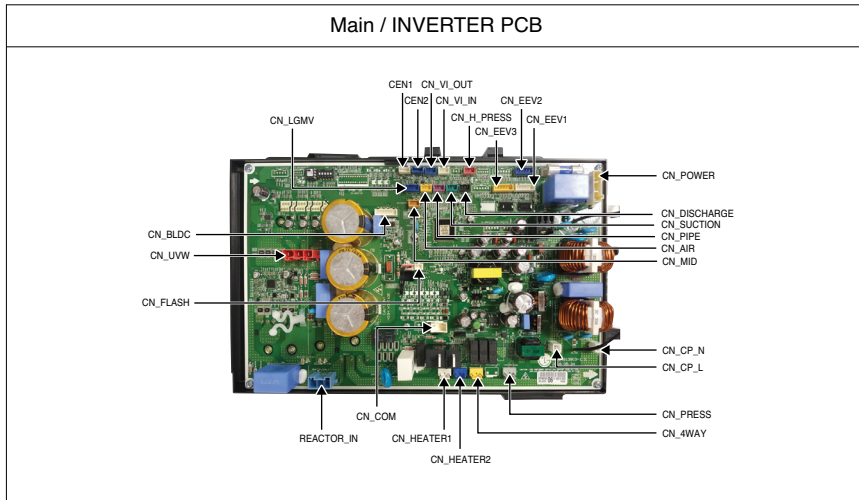

1.2 1Ø : 12 kW, 14 kW, 16 kW

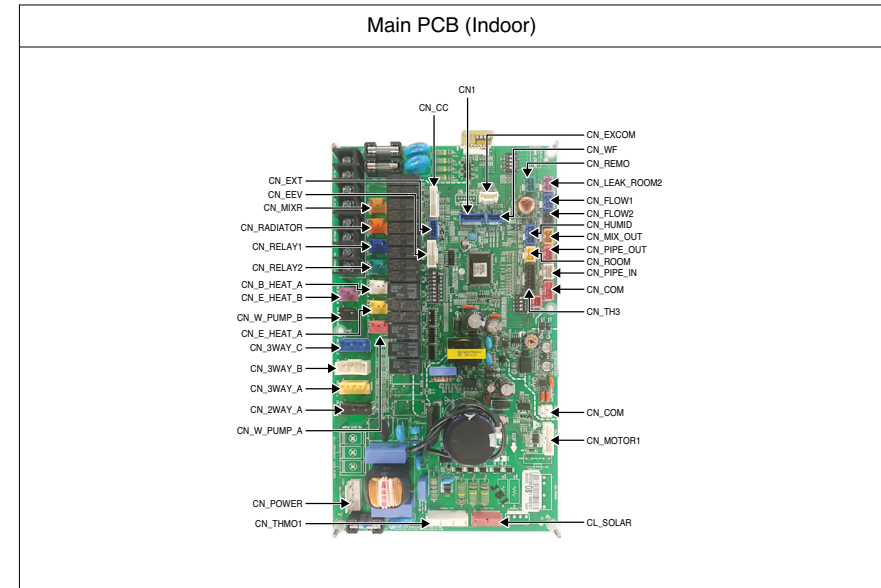
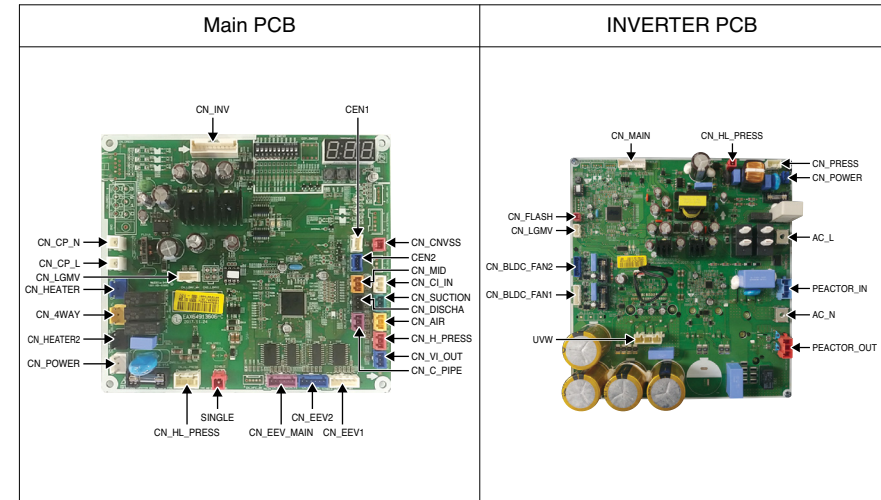

2. Error Code Check

Main PCB assembly(Inverter)

- Red LED means error no. 10's digit, and green LED means 1's digit, and when red and green simultaneously blink, it means 100's unit.

Ex) Inverter compressor IPM defect Error : error number 21

Error Code	Description	LED 1 (Red)	LED 2 (Green)
21	Inverter compressor IPM defect	2times	1time



1Ø, 5kW / 7kW / 9kW



1Ø, 12kW / 14kW / 16kW



3Ø, 12kW / 14kW / 16kW

1.3 3Ø : 12 kW, 14 kW, 16 kW

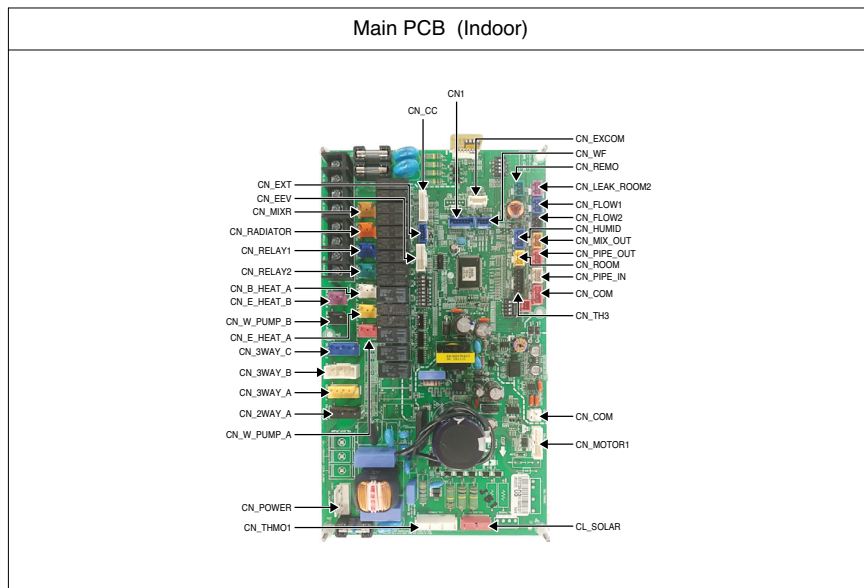
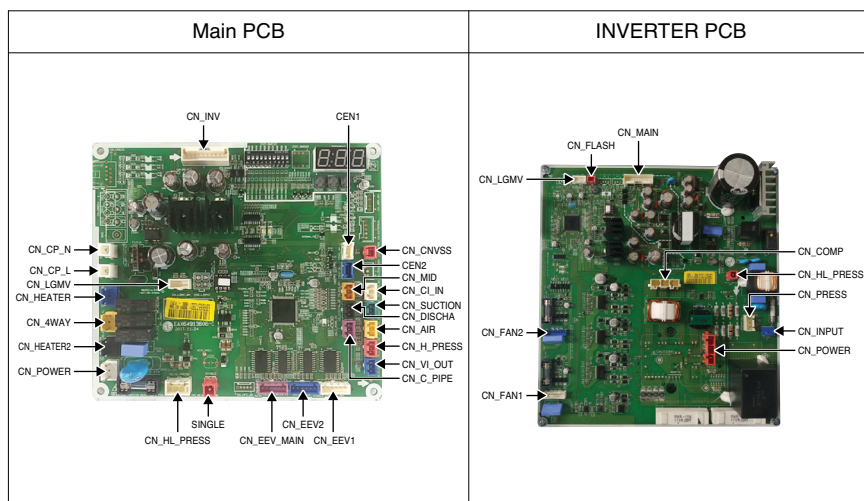

Error Code	Level	Description	Cause of Error
21	H-Trouble	DC Peak(IPM Fault)	IPM of inverter drive is abnormal or Inverter comp. is self-defective.
22	H-Trouble	Max. CT(RMS)	Power input of inverter PCB is exceeded. (1Φ : 29A, 3Φ : 13A)
23	H-Trouble	DC Link Low/High Voltage	DC link voltage is above 480 V / below 140 V.
24	H-Trouble	Low/High Pressure Switch Perception Error	Pressure switch is self-defective.
26	H-Trouble	Inverter Compressor No Position Error	Start-up of Compressor is abnormal(locked). Frequency of inverter is above 125 Hz or below 10 Hz in 60 seconds after start-up.
27	H-Trouble	PFC Fault Error	Over current is passed through PFC module.
29	H-Trouble	Compressor Over Current	Power input of inverter comp. is exceeded. (1Φ : 35A, 3Φ : 24A)
32	H-Trouble	High D-Pipe Temperature	Temperature of discharge pipe is abnormally high.
35	H-Trouble	Low Pressure Error	Evaporating pressure is excessively low.
41	H-Trouble	Problem in D-Pipe Temperature sensor	Discharge pipe temperature sensor of outdoor unit is open or short.
43	H-Trouble	Problem in High Pressure Sensor	High pressure sensor of outdoor unit is open or short.
44	H-Trouble	Problem in Outdoor air Temperature sensor	Outdoor air temperature sensor is open or short.
45	H-Trouble	Problem in Cond. Middle Pipe Temperature sensor	Cond. Middle pipe temperature sensor of outdoor unit is open or short.
46	H-Trouble	Problem in Suction Pipe Temperature sensor	Suction pipe temperature sensor of outdoor unit is open or short.
52	Error	PCB Communication Error(Inverter PCB ↔ main PCB)	It is failed to receive wired Inverter PCB signal in outdoor unit PCB.

Error Code	Level	Description	Cause of Error
53	H-Trouble	Bad communication between outdoor unit and indoor unit	It is failed to receive the signal from IDU.
54	H-Trouble	Open and Reverse Phase Error	Wiring fault is occurred. – reverse phase (only 3-phase model)
60	H-Trouble	EEPROM Error(Outdoor)	EEPROM is contacted on PCB incorrectly or EEPROM is self-defective.
61	H-Trouble	High Pressure Error	Condensation pressure is too high.
62	H-Trouble	High Heatsink Temperature	Temperature of heatsink or element is abnormally high.
65	H-Trouble	Problem in Heatsink Temperature sensor	Heatsink temperature sensor of outdoor unit is open or short.
67	O-Trouble	Fan Lock Error	Revolutions Per Minute (RPM) is lower than 40 in steady state.
114	H-Trouble	Problem in Vapor injection inlet temperature sensor	Vapor injection inlet pipe temperature sensor of outdoor unit is open or short.
115	H-Trouble	Problem in Vapor injection outlet temperature sensor	Vapor injection outlet pipe temperature sensor of outdoor unit is open or short.

Error Code	Title	Cause of Error	Normal condition
1	Problem in remote air sensor	<ul style="list-style-type: none"> Indoor PCB is self-defective. Wiring is wrong or imperfect. Condition of sensor is open or short Temperature sensor reaches the limitation. 	• Rair = 10 kΩ (unplugged) / Vair = 2.262 V DC(plugged)
2	Problem in refrigerant inlet(liquid) side sensor		• Rrin = 5 kΩ (unplugged) / Vrin = 2.232 V DC (plugged)
6	Problem in refrigerant outlet(gas) side sensor		• Rrout = 5 kΩ (unplugged) / Vrout = 2.232 V DC (plugged)
8	Problem in water tank sensor		• Rtank = 5 kΩ (unplugged) / Vtank = 2.232 V DC (plugged)
13	Problem in solar pipe sensor		• Rsol = 10 kΩ (unplugged) / Vsol = 2.262 V DC(plugged)
17	Problem in Water-inlet sensor		• Rwin = 5 kΩ (unplugged) / Vwin = 2.232 V DC (plugged)
18	Problem in Water-outlet sensor		• Rwout = 5 kΩ (unplugged) / Vwout = 2.232 V DC (plugged)
19	Problem in electric backup heater outlet sensor		• Rrwout = 5 kΩ (unplugged) / Vrwout = 2.232 V DC (plugged)

Check Flow Chart (A)

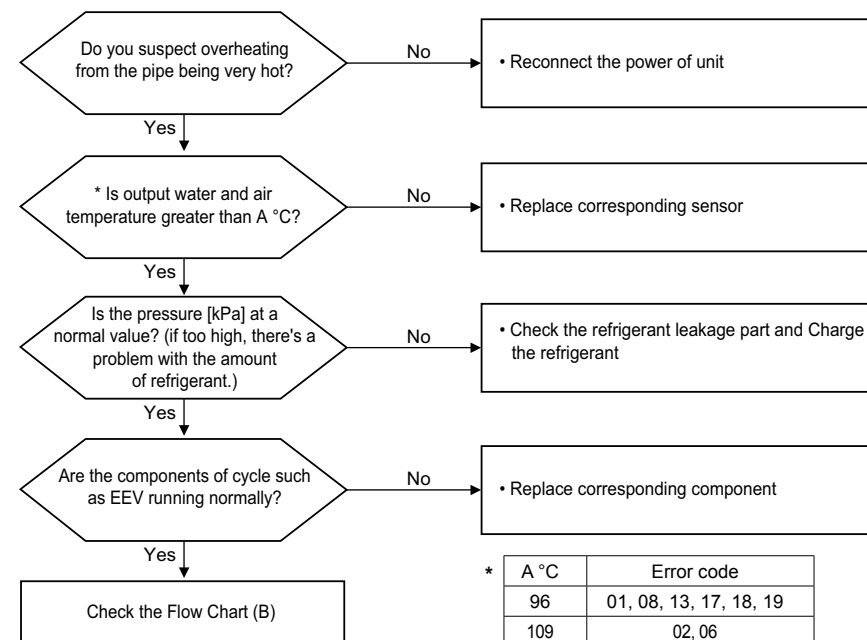

Check Flow Chart (B)

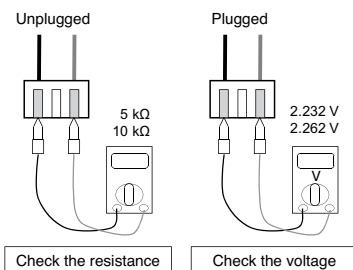
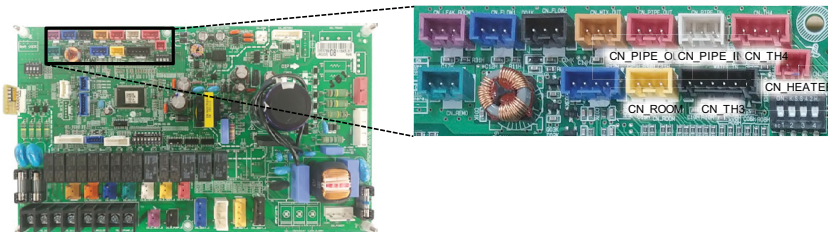
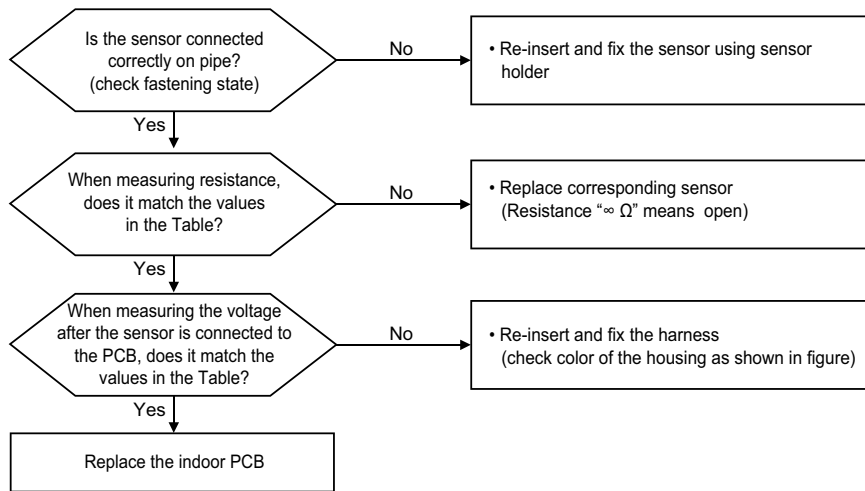

Error code	PCB mark	Housing color / pin
CH 01	CN_ROOM	Yellow / 3
CH 02	CN_PIPE_IN	White / 3
CH 06	CN_PIPE_OUT	Red / 3
CH 08	CH_TH4	Red / 4
CH 13	CH_TH4	Red / 4
CH 17	CN_TH3	Black / 6
CH 18	CN_TH3	Black / 6
CH 19	CN_HEATER	Red / 2

Error Code	Title	Cause of Error	Normal condition
03	Bad communication between remote controller and indoor unit	<ul style="list-style-type: none"> Indoor PCB or remote controller is self-defective. Wiring is wrong or imperfect 	<ul style="list-style-type: none"> The cable is attached properly. The remote controller is properly supplied with 12 V DC power.

Check Flow Chart

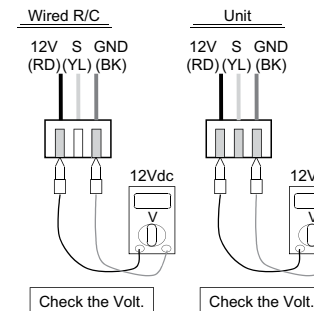
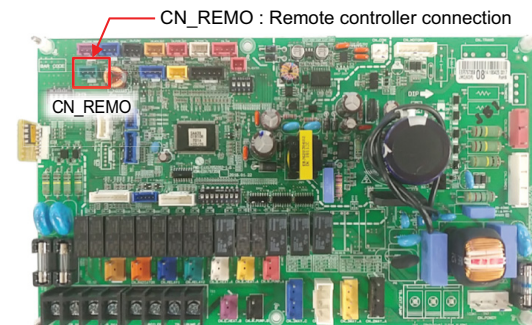
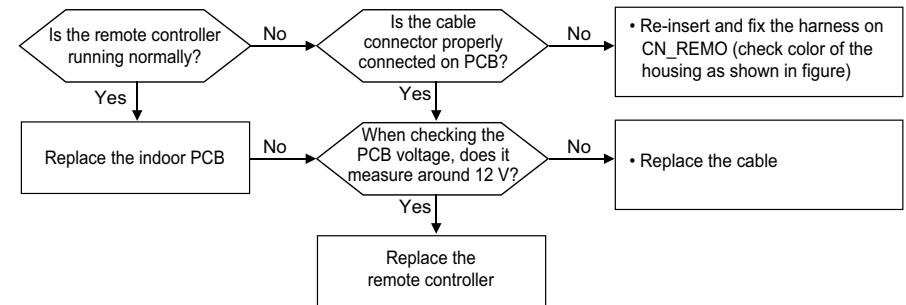

Error Code	Title	Cause of Error	Normal condition
05	Bad communication between outdoor unit and indoor unit	<ul style="list-style-type: none"> Indoor PCB or outdoor PCB is self-defective. Communication cable is faulty. Connection is wrong or imperfect. 	<ul style="list-style-type: none"> Communication is possible when the cable is properly connected between the indoor and outdoor units.

Check Flow Chart

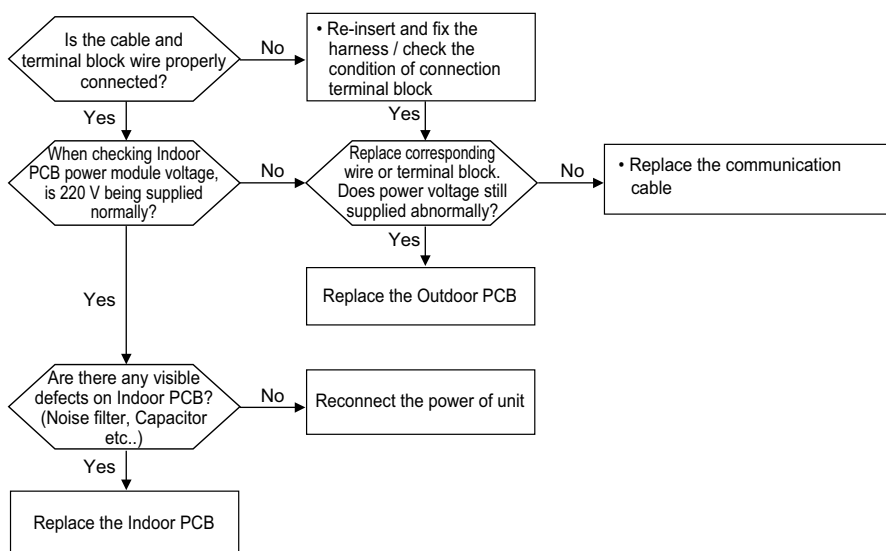

Error Code	Title	Cause of Error	Normal condition
09	PCB Program (EEPROM) Fault	<ul style="list-style-type: none"> EEPROM is faulty. Condition of soldering is poor. Option PCB is inserted on Indoor PCB imperfectly. 	<ul style="list-style-type: none"> The option PCB is properly inserted into the Indoor PCB.

Check Flow Chart

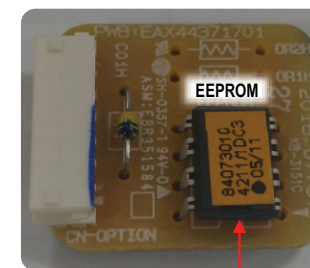
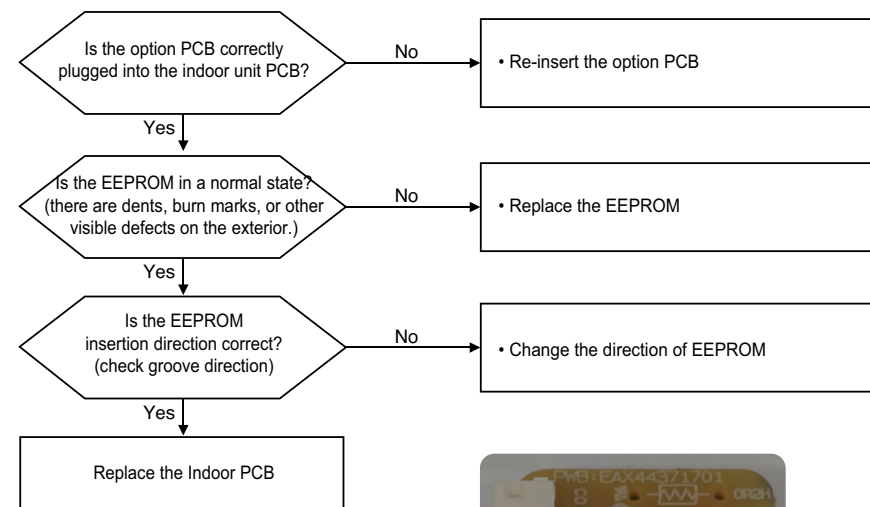

Check groove direction

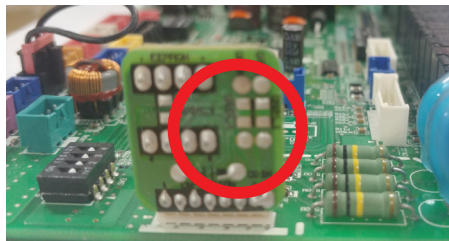
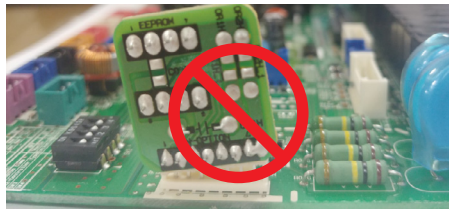
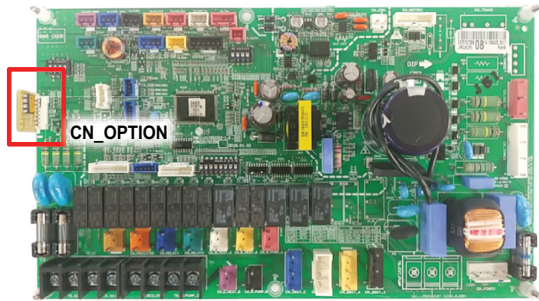

Error Code	Title	Cause of Error	Normal condition
10	BLDC Water pump Lock	<ul style="list-style-type: none"> Indoor PCB or harness is self-defective. Connection is wrong or imperfect. There is the cycle problem like leakage. 	<ul style="list-style-type: none"> The harnesses of the power module and communication module are properly connected.

Check Flow Chart (A)

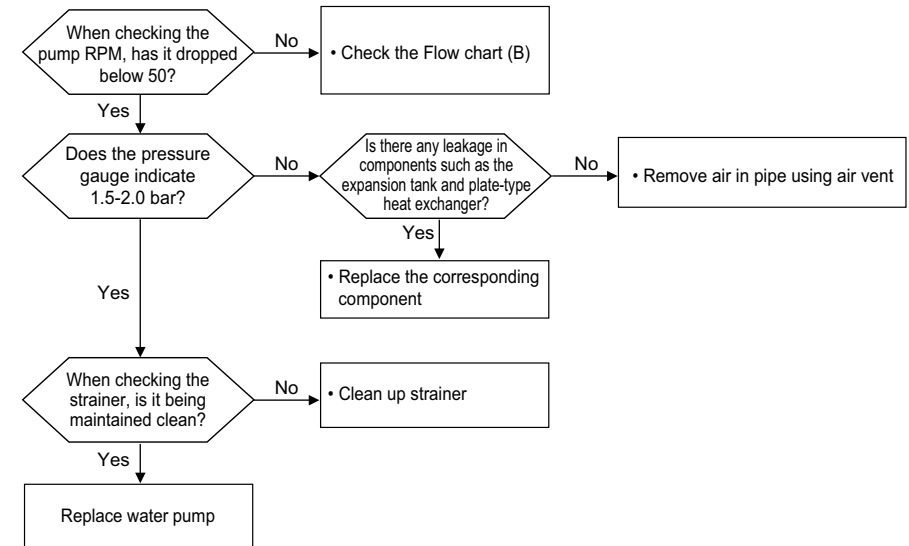

Check Flow Chart (B)

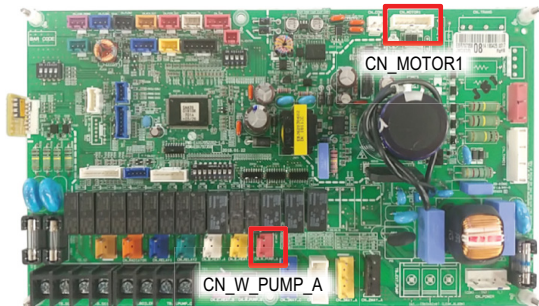
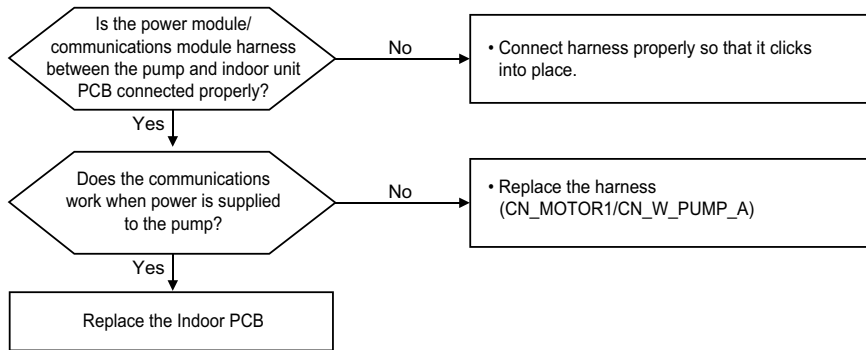

Error Code	Title	Cause of Error	Normal condition
14	Problem in flow switch	<ul style="list-style-type: none"> Water flow rate is less than 15LPM. Water pump or flow switch is self-defective. Dip switch setting is incorrect. 	<ul style="list-style-type: none"> Flow switch should be closed while internal water pump is working or DIP switch No. 5 of main PCB(Heater) is set as ON Flow switch should be open while internal water pump is not working.

Check Flow Chart (A)

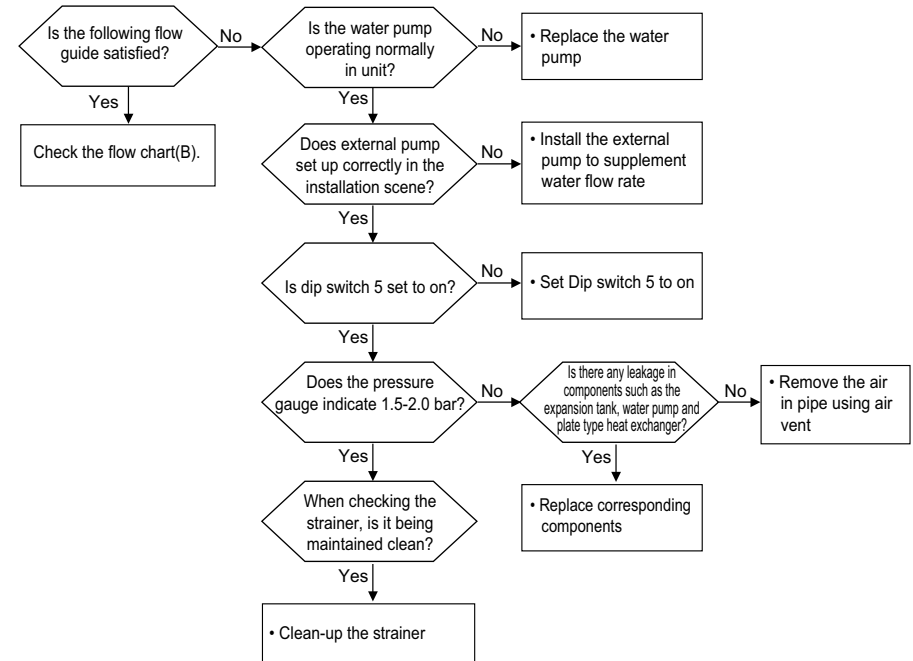

Flow-rate check guide

Before replacing flow switch, check the below contents to determine whether flow switch is problem or not. Below contents are trouble except flow switch problem.

<Ensure flow rate>

- Water temperature difference is about 3 to 6 degrees in rated flow rate.
- Please refer to the flow-rate guide below.
- Please set lower than the temperature indicated below.
- * Check the water temperature difference between 15 and 30 minutes after starting the product.

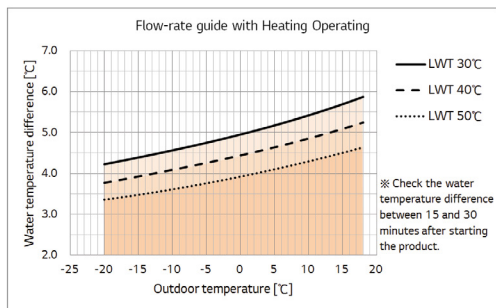
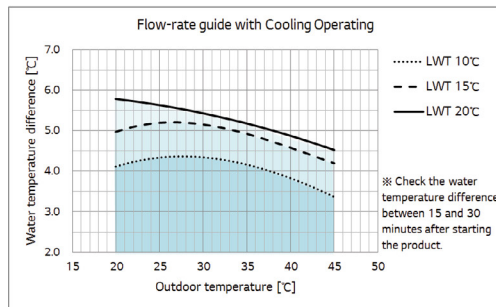

Check Flow Chart (B)

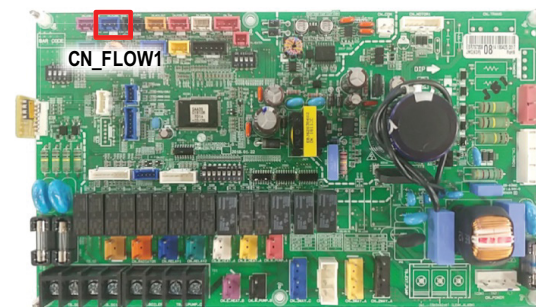
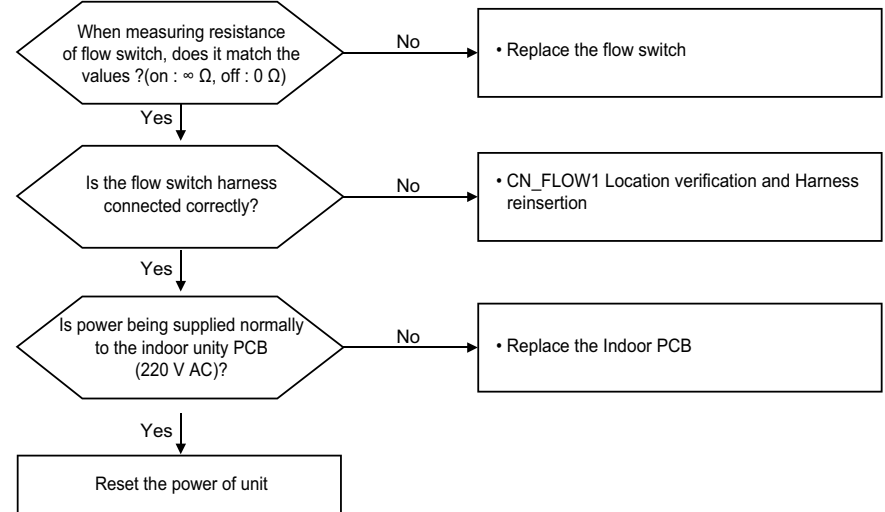

Error Code	Title	Cause of Error	Normal condition
15	Water pipe strange overheat	<ul style="list-style-type: none"> • Temperature of water pipe is too high. • Temperature sensor is faulty. • Indoor PCB is self-defective. 	<ul style="list-style-type: none"> • The harness is attached properly. • Sensor voltage and resistance is normal.

Check Flow Chart (A)

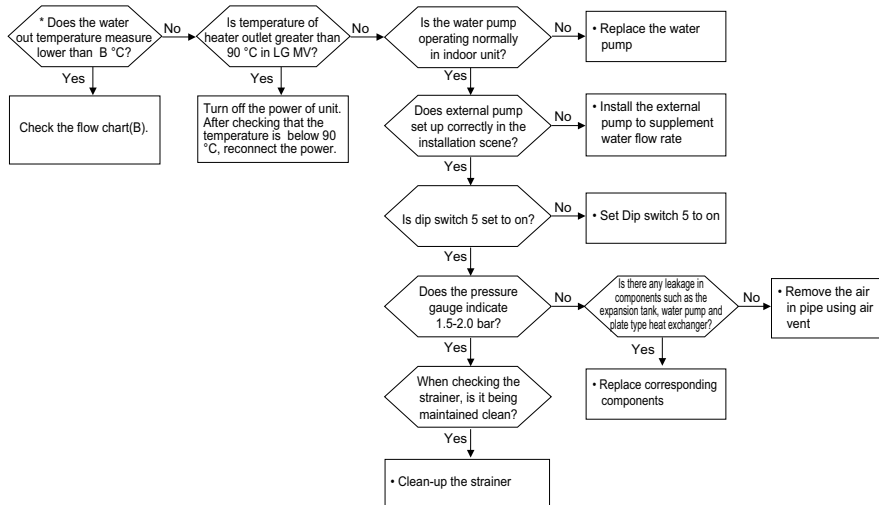

*

Model	B °C
Split (heater integrated)	72
Monobloc (heater option)	67

Check Flow Chart (B)

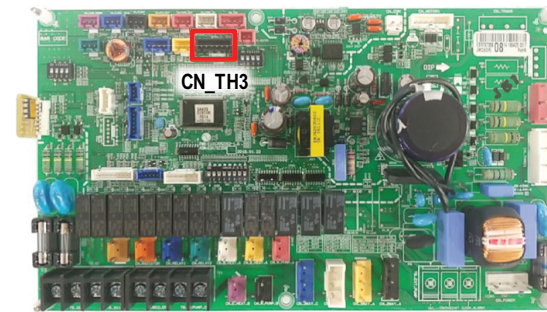
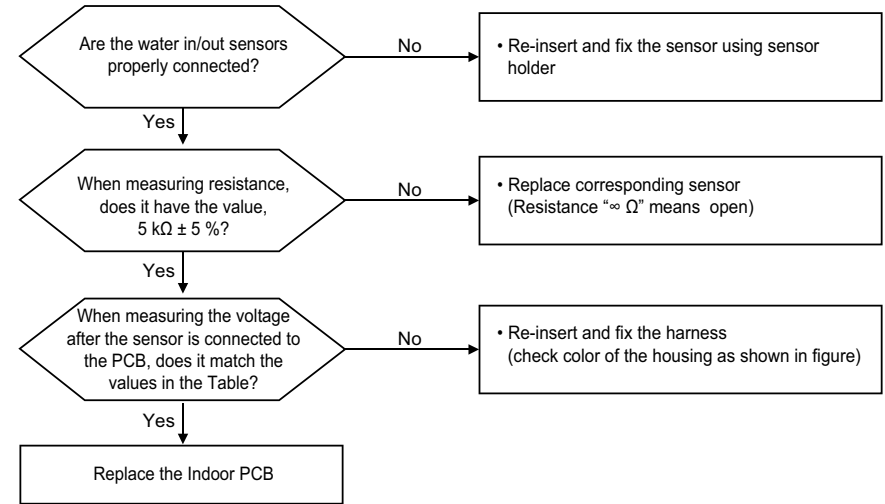

Error Code	Title	Cause of Error	Normal condition
16	Problems in sensors	<ul style="list-style-type: none"> Three sensors caused an error at the same time. Split : Water in + Water out + E/heater out Monobloc : Water in + Water out 	<ul style="list-style-type: none"> The harness is attached properly.

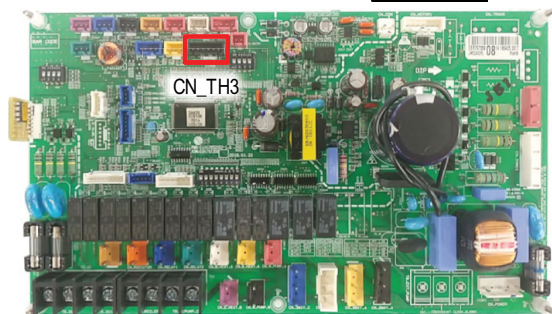
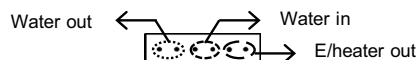
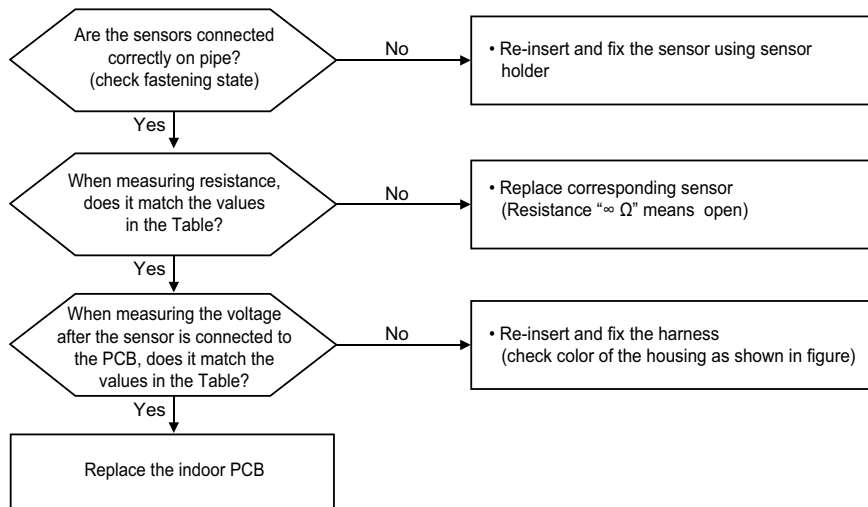

Error Code	Title	Cause of Error	Normal condition
20	Electric heater strange overheat	<ul style="list-style-type: none"> Fuse of electric heater is blown due to overheat. 	<ul style="list-style-type: none"> The heater output water temperature is below 90 °C and the fuse is intact.

Check Flow Chart

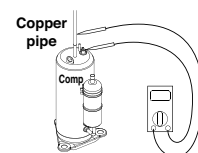
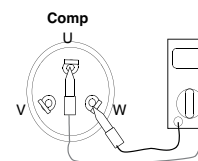
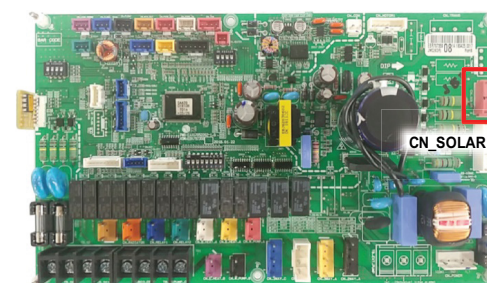
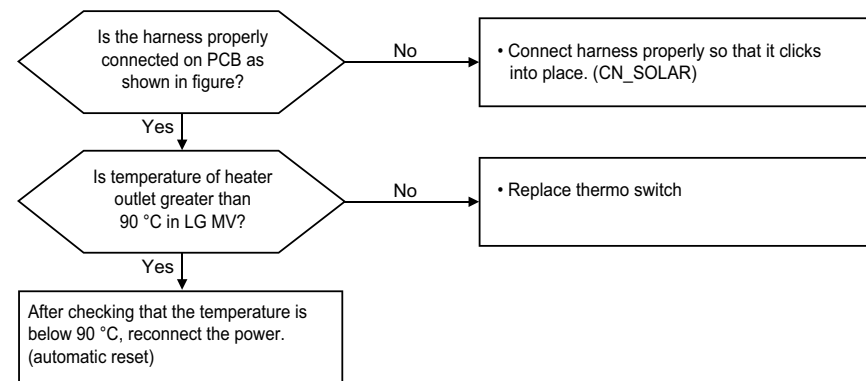

Model		RJB036MAA	GJT240MAA	GPT442MAA
Windings Resistance (at 25 °C)	U-V	0.529 ± 7% Ω	0.628 ± 7% Ω	0.724 ± 7% Ω
	V-W	0.529 ± 7% Ω	0.628 ± 7% Ω	0.724 ± 7% Ω
	W-U	0.529 ± 7% Ω	0.628 ± 7% Ω	0.724 ± 7% Ω

Terminal	Insulation Resistance
U-panel	≥ 10 MΩ
V-panel	≥ 10 MΩ
U-panel	≥ 10 MΩ

Error Code	Title	Cause of Error	Normal condition
21	DC Peak(IPM Fault)	<ul style="list-style-type: none"> • Comp. is over-current. • BLDC motor is damaged. • PCB IPM is overheated • Pipe is clogging. • Inverter PCB is self-defective. 	<ul style="list-style-type: none"> • The compressor connection state is okay. • Power is supplied stably.
22	Max. CT(RMS)		
26	Inverter Compressor No Position Error	<ul style="list-style-type: none"> • Fail to position sensing • Fail to compressor start-up 	<ul style="list-style-type: none"> • Fail to position sensing • Fail to compressor start-up
29	Compressor Over Current=	<ul style="list-style-type: none"> • Overcurrent in inverter compressor 	<ul style="list-style-type: none"> • Overcurrent in inverter compressor

Check Flow Chart

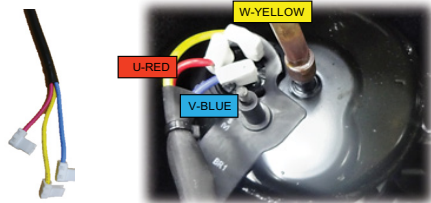
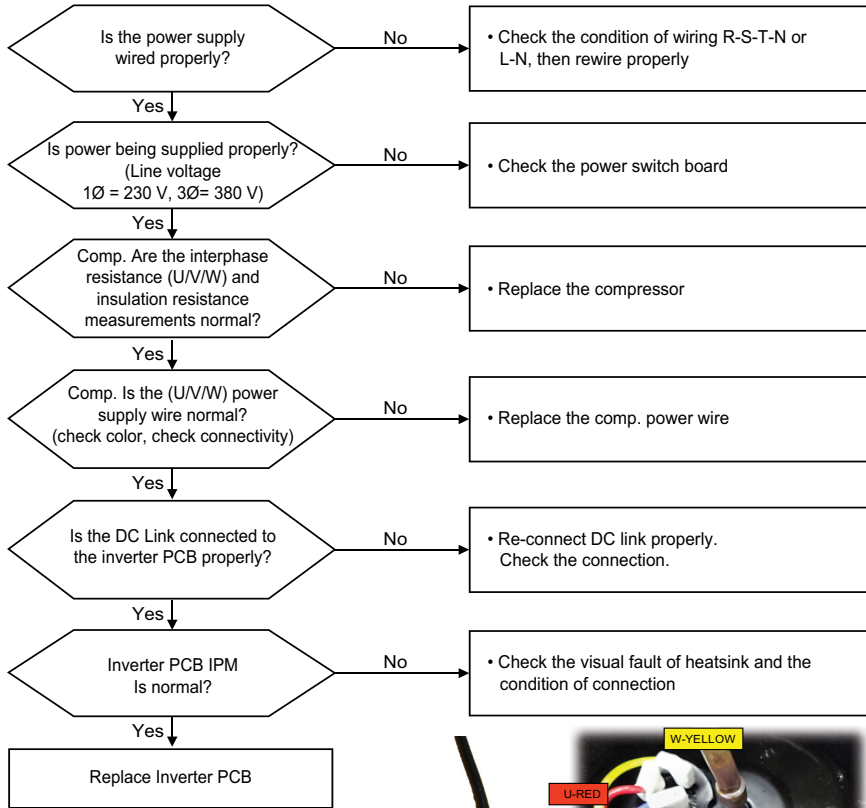

Check Point (CH21)

▶ 1Ø, 5kW / 7kW / 9kW

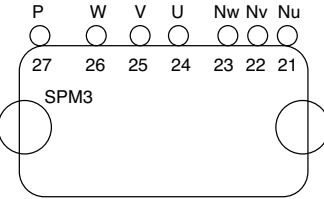
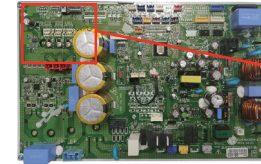

1. Wait PCB(Inverter) DC voltage is discharged after main power off.
2. Pull out U, V, W COMP connector.
3. Set multi tester to resistance mode.
4. If the value between P and N terminal of IPM is short(0Ω) or open(hundreds MΩ), PCB(Inverter) needs to be replaced.(IPM damaged)
5. Set the multi tester to diode mode.
6. In case measured value is different from the table, PCB(Inverter) needs to be replaced. (PCB(Inverter) damaged).

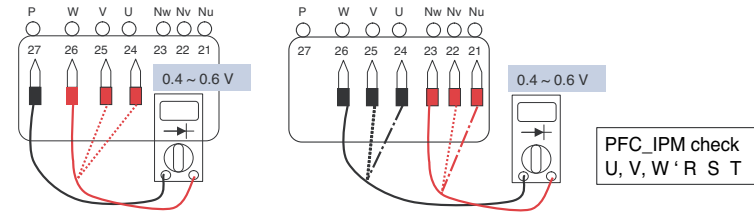

▶ 1Ø, 12kW / 14kW / 16kW

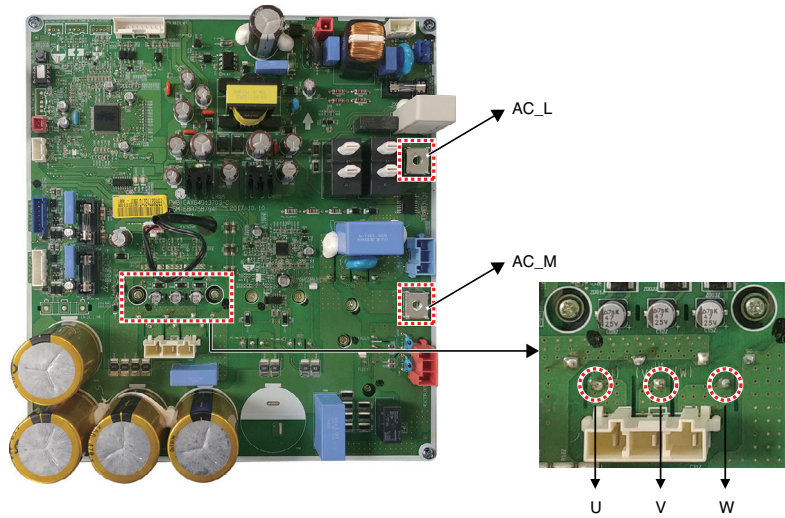

1. Wait PCB(Inverter) DC voltage is discharged after main power off.
2. Pull out AC(L), AC(N) connectors and U,V,W COMP Connector.
3. Set multi tester to resistance mode.
4. If the value between P and N terminal of IPM is short(0Ω) or open(hundreds $M\Omega$), PCB needs to be replaced.(IPM damaged)
5. Set the multi tester to diode mode.
6. In case measured value is different from the table, PCB(Inverter) needs to be replaced.(PCB damaged).

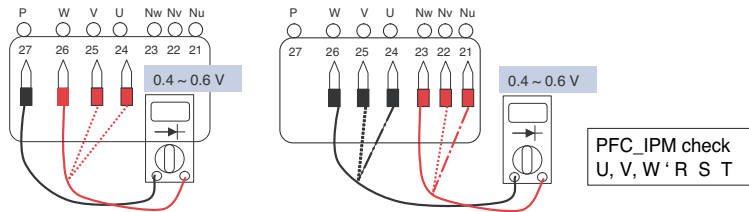

▶ 3Ø, 12kW / 14kW / 16kW

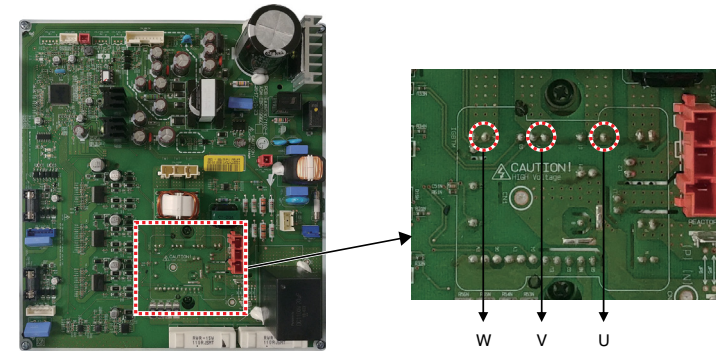

1. Wait PCB(Inverter) DC voltage is discharged after main power off.
2. Pull out AC(L), AC(N) connectors and U,V,W COMP Connector.
3. Set multi tester to resistance mode.
4. If the value between P and N terminal of IPM is short(0Ω) or open(hundreds $M\Omega$), PCB needs to be replaced.(IPM damaged)
5. Set the multi tester to diode mode.
6. In case measured value is different from the table, PCB(Inverter) needs to be replaced.(PCB damaged).

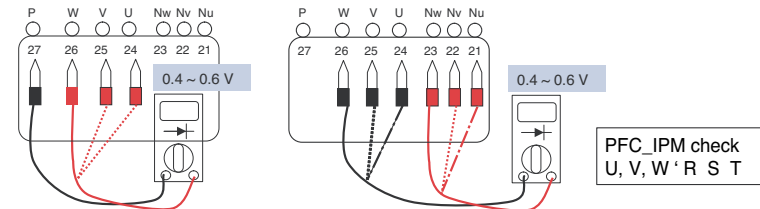

Check Point (CH22)

1. Check the power source.(230 V \pm 15 %)
2. Check the fan operation is right.
3. Check the current.
4. Check the install condition.
5. Check the CT Sensor Output signal

(1 \emptyset , 5 kW / 7 kW / 9 kW - Check output the CT Sensor : DC 2.5 \pm 0.2 V

1 \emptyset , 12 kW / 14 kW / 16 kW- Check output pin 2.3 of the CT Sensor : DC 2.5 \pm 0.2 V

3 \emptyset , 12 kW / 14 kW / 16 kW - Check input_current of the CT sensor : DC 2.5 \pm 0.2 V)

▶ 1 \emptyset , 5kW / 7kW / 9kW

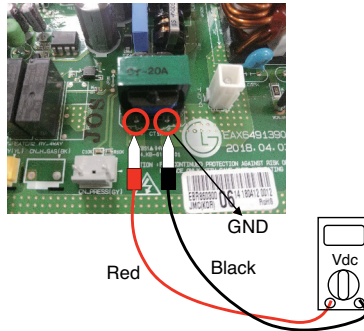
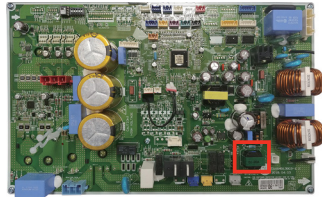

<CT Sensing Check Point>

▶ 1 \emptyset , 12kW / 14kW / 16kW

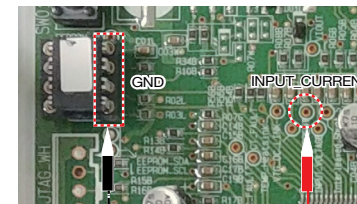
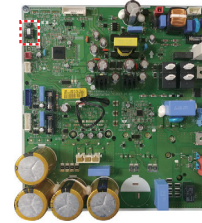

▶ 3 \emptyset , 12kW / 14kW / 16kW

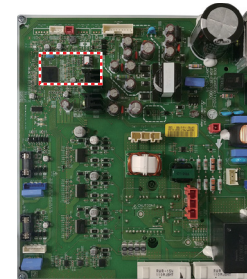

<Inverter PCB>

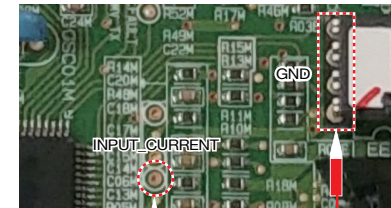

<CT Sensing Check Point >

Check Point (CH26)

1. IPM Check

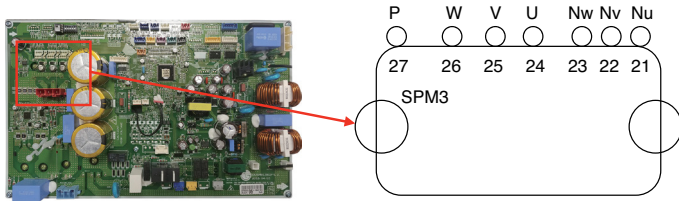

1. Wait PCB DC voltage is discharged after main power off.
2. Pull out V, V, W COMP connector.
3. Set multi tester to resistance mode.
4. If the value between P and N terminal of IPM is short(0Ω) or open(hundreds $M\Omega$), PCB needs to be replaced.(IPM damaged)
5. Set the multi tester to diode mode.
6. In case measured value is different from the table, PCB needs to be replaced. (PCB damaged).

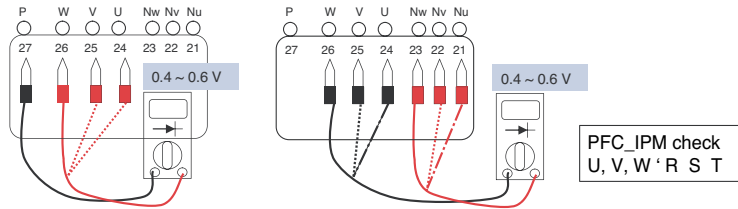

2. CT Sensing Check

- Inspecting PCB phase current sensing circuit
1. Set Multi-tester DC voltage measurement mode.
 2. Measure the below measuring point DC voltages at Power-on standby state.
 3. If the measurements are outside $DC\ 2.5V \pm 0.2V$, the parts are decided as burned.

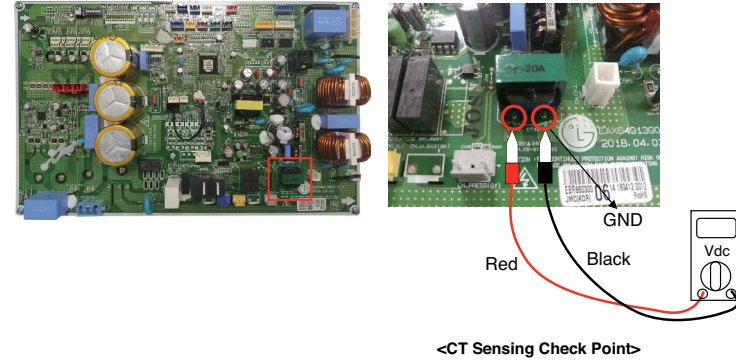

3. Connector Check

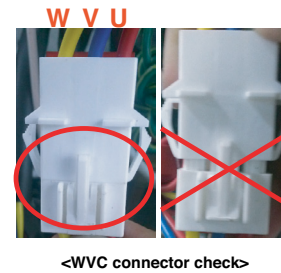

Error Code	Title	Cause of Error	Normal condition
23	DC Link Low/High Voltage	<ul style="list-style-type: none"> Charge and supply of DC voltage is abnormal. Capacitor or relay is default. Inverter PCB is self-defective. 	<ul style="list-style-type: none"> DC Link is properly connected to the inverter PCB.
27	PFC Fault Error		

Check Flow Chart

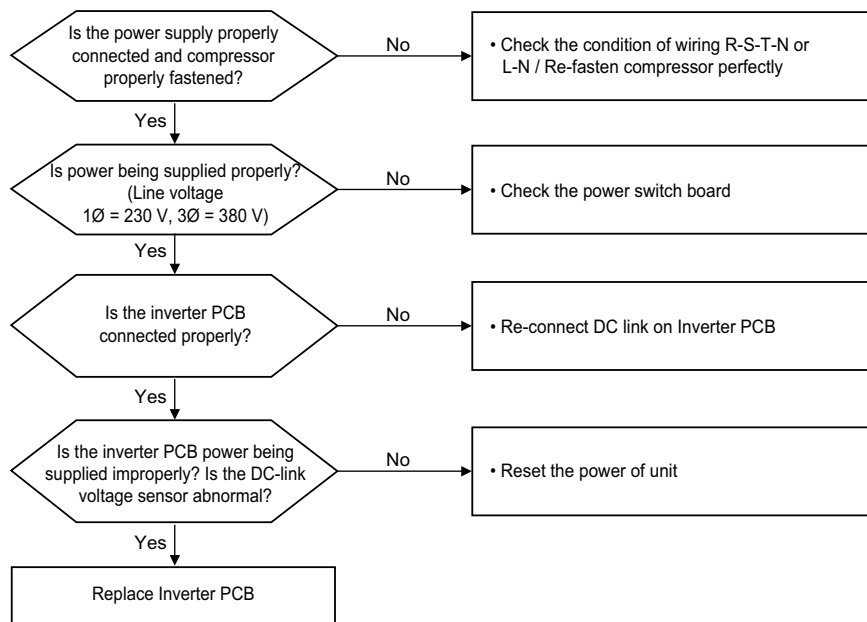

Check Point

1. Check the WCN_P(L),P(N) Connection condition at the main PCB(Heater). (Refer to wiring diagram)
2. Check the DC Link voltage at not operating(280 V↑)
3. Check the DC Link voltage at Comp operating(340 V↑)
4. Check DC Link Sensing Signal(ZHBW**6A0) :2.4~2.8 V (Refer the Picture)
5. Check DC Link Sensing Signal(ZHBW**8A0) :0.4~0.6 V (Refer the Picture)

* 1Ø, 5kW / 7kW / 9kW

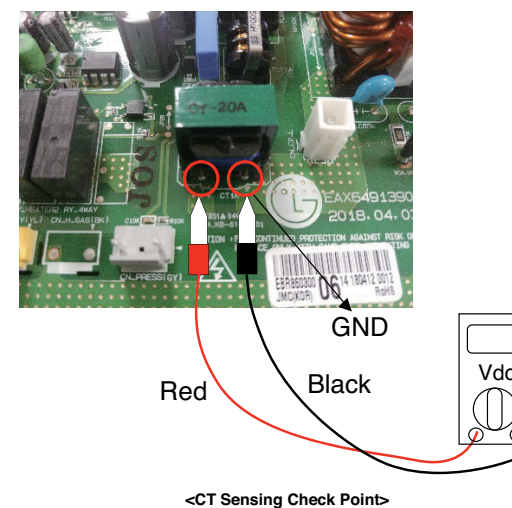
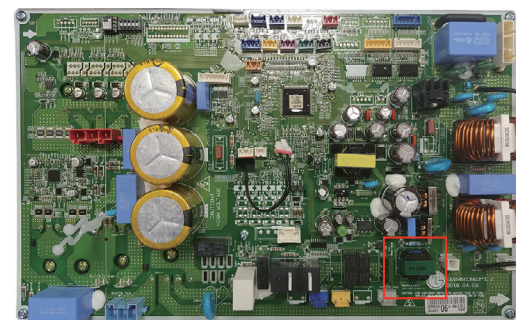

▶ 1Ø, 12kW / 14kW / 16kW

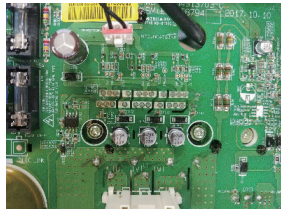
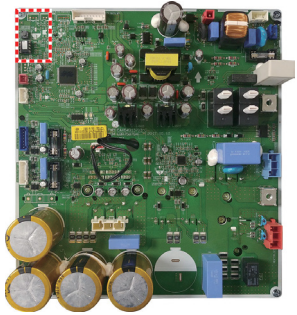

▶ 3Ø, 12kW / 14kW / 16kW

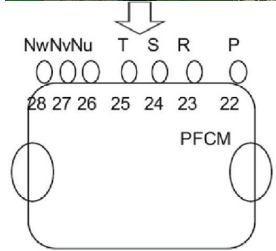
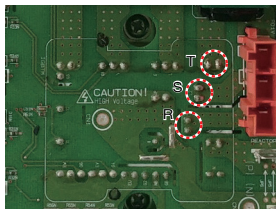
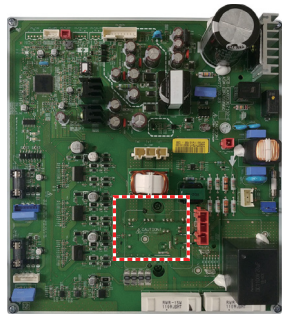

[PFCM Pin Arrangement and Pin Numbers]

Error Code	Title	Cause of Error	Normal condition
24	Low/High Pressure Switch Perception Error	<ul style="list-style-type: none"> • Pressure switch is self-defective. • Outdoor PCB is self-defective. • Cycle problem occurs in operation.(Refrigerant flow rate, Fan lock, Faulty of EEV) 	<ul style="list-style-type: none"> • The harness between the outdoor PCB and pressure switch is properly connected.
35	Low Pressure Error	<ul style="list-style-type: none"> • Evaporating pressure is too low. 	

Check Flow Chart

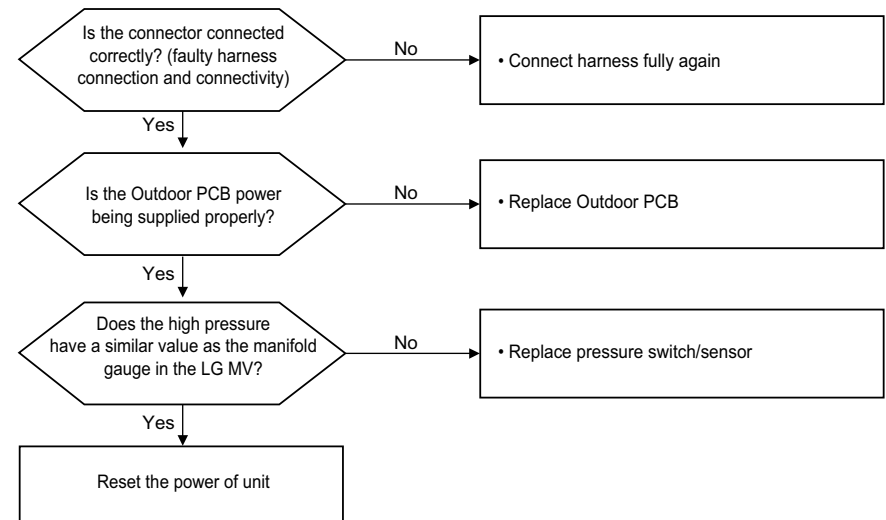

Error Code	Title	Cause of Error	Normal condition
32	High D-Pipe Temperature	<ul style="list-style-type: none"> • Temperature of D-pipe is too high. • Refrigerant amount is shortage. • EEV operation is abnormal. 	<ul style="list-style-type: none"> • The sensor is properly inserted into the Outdoor PCB.

Check Flow Chart (A)

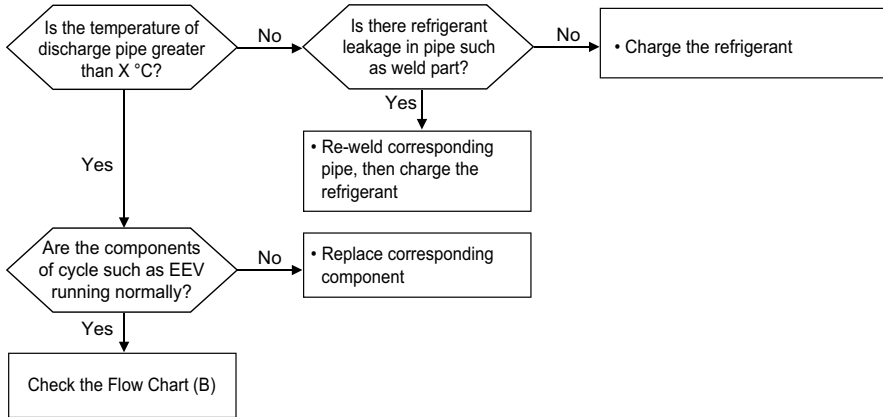

Model	X °C
Split	105
Monobloc	110

Check Flow Chart (B)

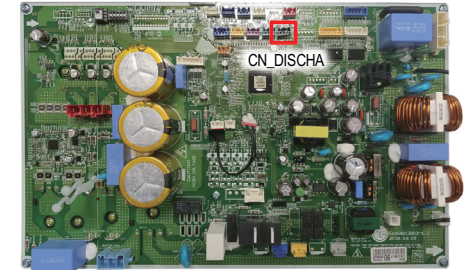
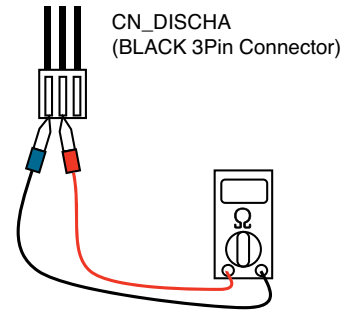
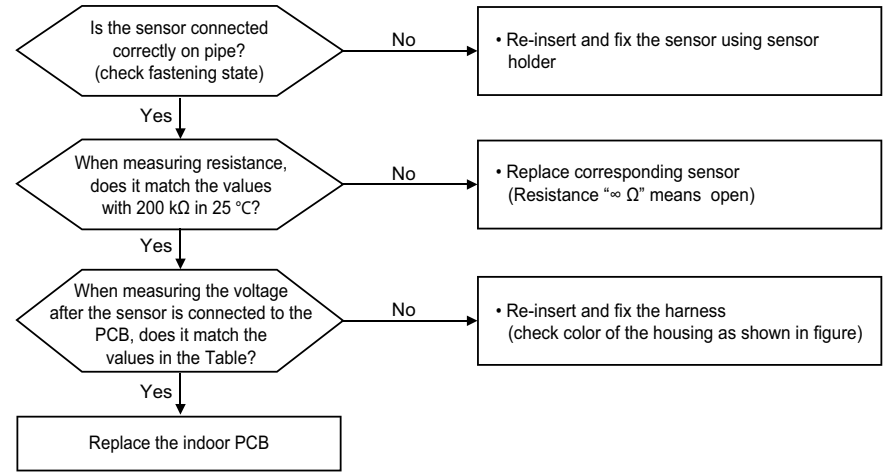

Error Code	Title	Cause of Error	Normal condition
41	Problem in D-Pipe Temperature sensor	<ul style="list-style-type: none"> Outdoor PCB is self-defective. Wiring is wrong or imperfect. Condition of sensor is open or short Temperature sensor reaches the limitation 	<ul style="list-style-type: none"> Rrin = 200 kΩ (unplugged) / Vrin = 4.587 V DC (plugged)
44	Problem in Outdoor air Temperature sensor		<ul style="list-style-type: none"> Rtank = 10 kΩ (unplugged) / Vtank = 2.262 V DC (plugged)
45	Problem in Cond. Middle Pipe Temperature sensor		<ul style="list-style-type: none"> Rsol = 5 kΩ (unplugged) / Vsol = 2.232 V DC (plugged)
46	Problem in Suction Pipe Temperature sensor		<ul style="list-style-type: none"> Rwin = 5 kΩ (unplugged) / Vwin = 2.232 V DC (plugged)
114	Problem in Vapor injection inlet temperature sensor		<ul style="list-style-type: none"> Rwout = 5 kΩ (unplugged) / Vwout = 2.232 V DC (plugged)
115	Problem in Vapor injection outlet temperature sensor	<ul style="list-style-type: none"> Rwout = 5 kΩ (unplugged) / Vwout = 2.232 V DC (plugged) 	

Check Flow Chart (A)

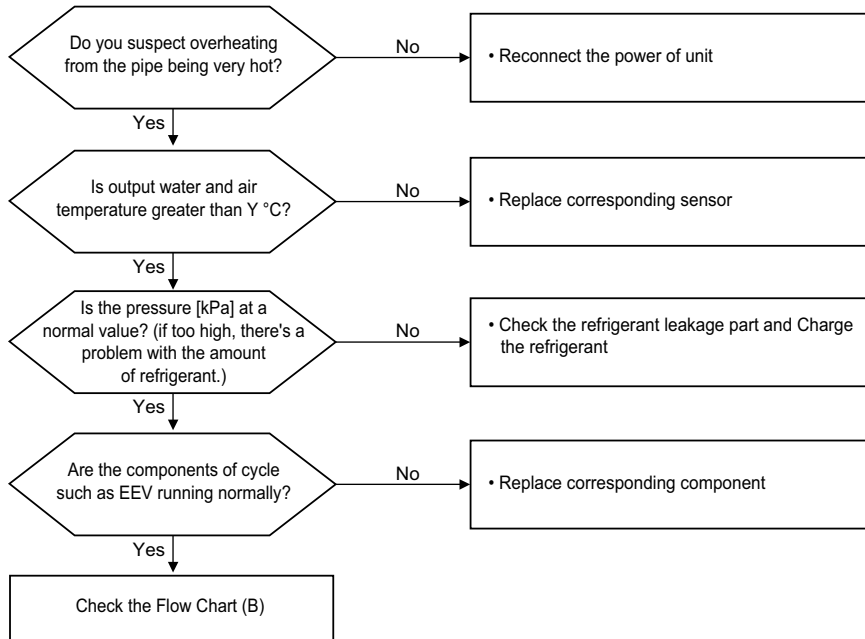

Y °C	Error Code
93.8	44
96.2	45, 46, 114, 115
146	41

Check Flow Chart (B)

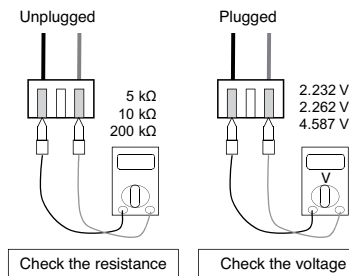
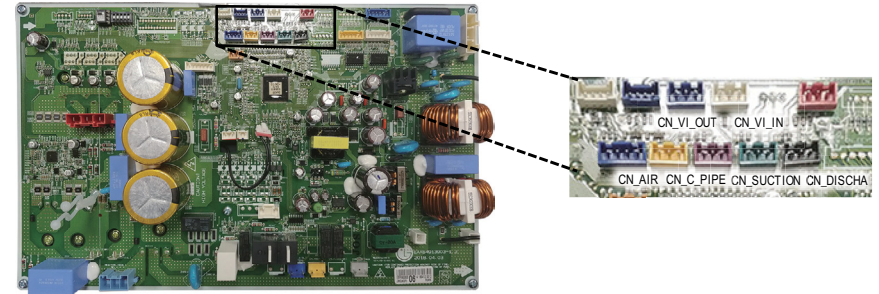
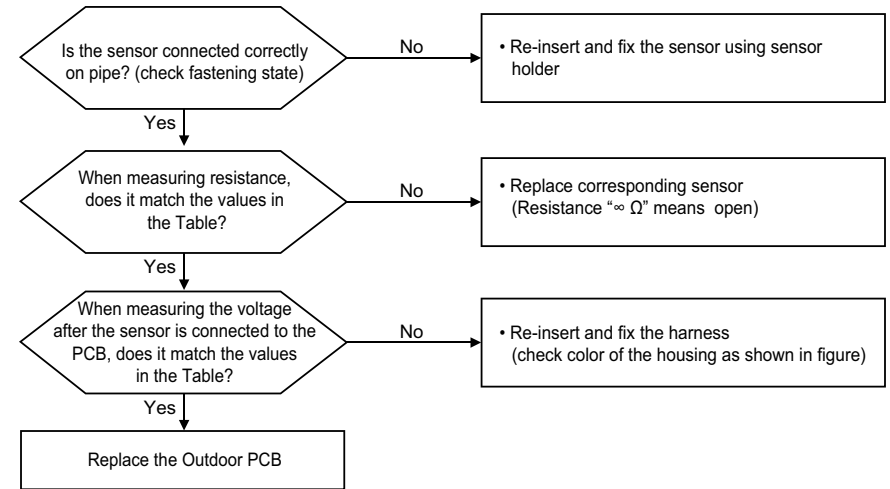

Error code	PCB mark	Housing color / pin
CH 41	CN_DISCHA	Black / 3
CH 44	CN_AIR	Yellow / 3
CH 45	CN_C_PIPE	Violet / 3
CH 46	CN_SUCTION	Green / 3
CH 114	CN_VI_IN	White / 3
CH 115	CN_VI_OUT	Blue / 3

Error Code	Title	Cause of Error	Normal condition
43	Problem in High Pressure Sensor	<ul style="list-style-type: none"> Outdoor PCB is self-defective. Condition of sensor is open or short 	<ul style="list-style-type: none"> The pressure sensor is properly inserted into the Outdoor PCB.

Check Flow Chart

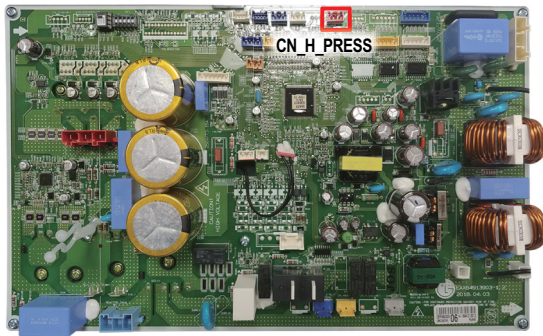
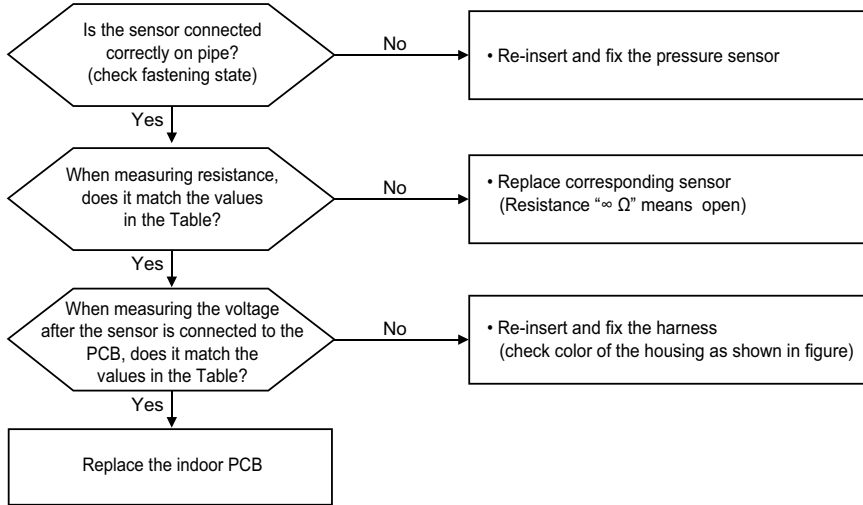

Error Code	Title	Cause of Error	Normal condition
52	PCB Communication Error(Inverter PCB ↔ main PCB)	<ul style="list-style-type: none"> Main PCB or Inverter PCB is self-defective. Connection is wrong or imperfect 	<ul style="list-style-type: none"> The cable is properly connected between the main and inverter PCB..

Check Flow Chart

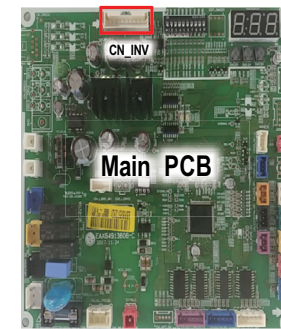
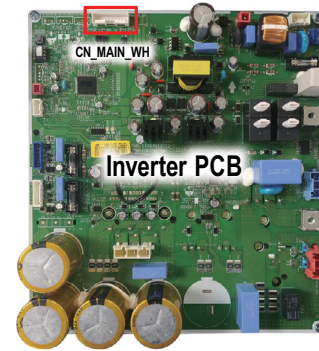
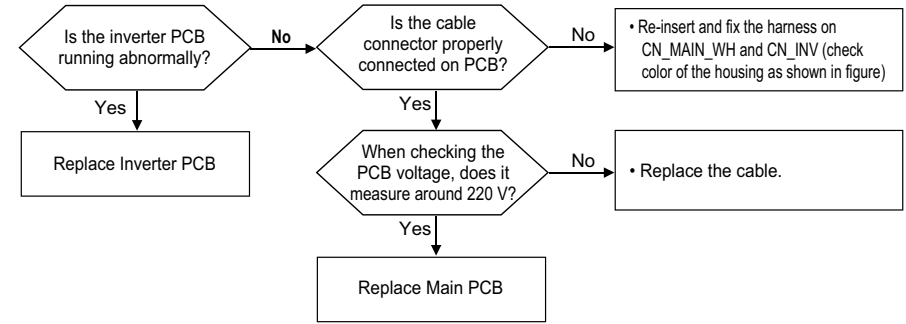

Error Code	Title	Cause of Error	Normal condition
53	Bad communication between outdoor unit and indoor unit	<ul style="list-style-type: none"> Indoor PCB or outdoor PCB is self-defective. Communication cable is faulty. Connection is wrong or imperfect. 	<ul style="list-style-type: none"> Communication is possible when the cable is properly connected between the indoor and outdoor units.

Check Flow Chart

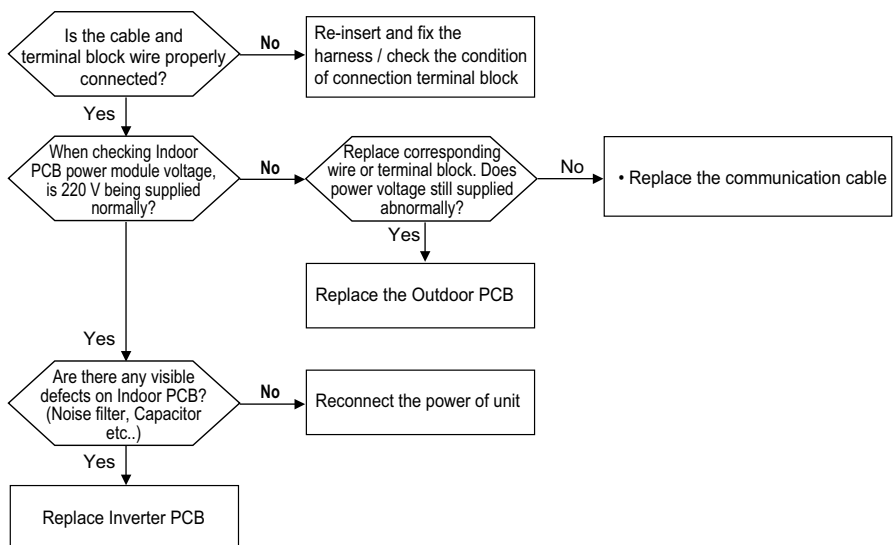

Error Code	Title	Cause of Error	Normal condition
54	Open and Reverse Phase Error	<ul style="list-style-type: none"> R-S-T wiring is wrong Fuse is broken in input voltage side. 	<ul style="list-style-type: none"> R-S-T wiring is normal Power voltage is normal

Check Flow Chart

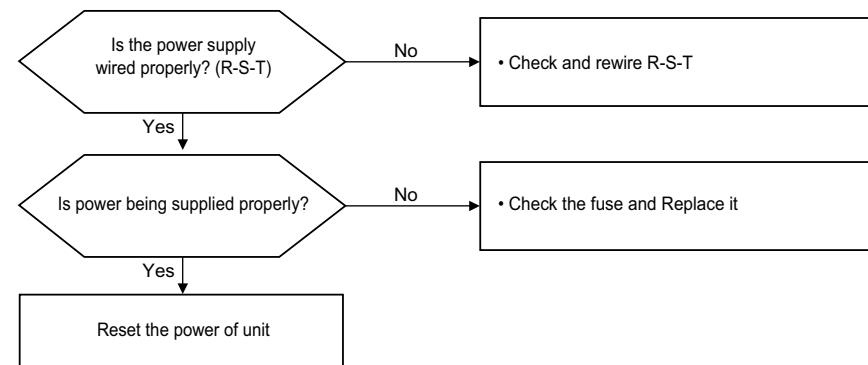

Check Point

▶ 3Ø, 12kW / 14kW / 16kW

■ **Judgment Method of R,S,T phase loss**

- Set the tester in AC voltage measurement mode (The part having wave pattern)
- The part that does not generate voltage was upgraded.
- Power module requires checking.

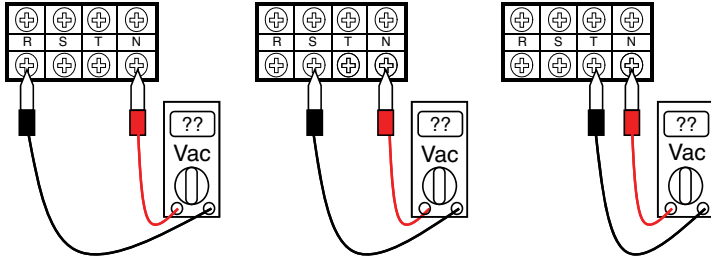

■ **Judgment method of open and reverse phase of R,S,T**

- Operation with replacement of R and S phases only

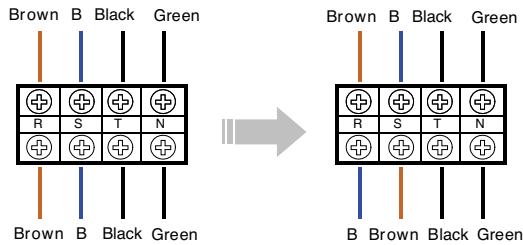

Error Code	Title	Cause of Error	Normal condition
60	EEPROM Error(Outdoor)	<ul style="list-style-type: none"> • EEPROM is faulty. • Condition of soldering is poor. • Outdoor PCB is self-defective. 	<ul style="list-style-type: none"> • EEPROM is properly fixed into the Indoor PCB.

Check Flow Chart

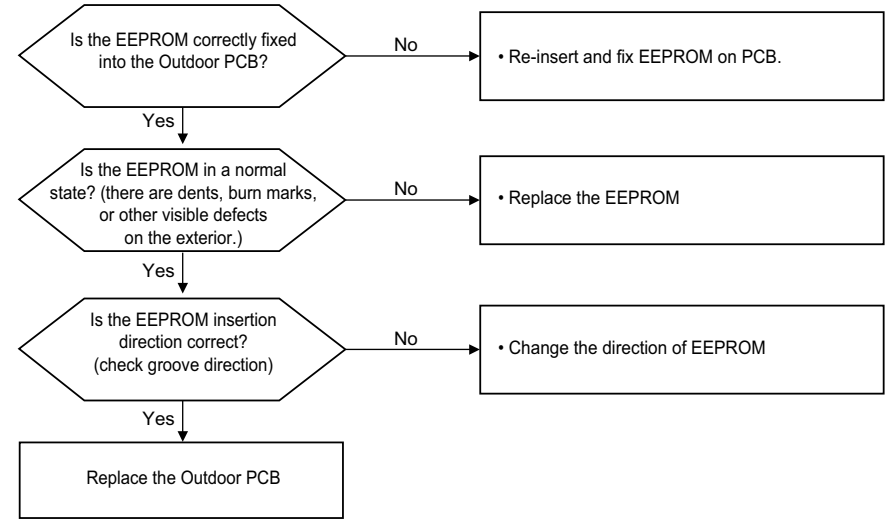

Check Point

- Check the EEPROM Check sum & Direction

▶ 1Ø, 5kW / 7kW / 9kW

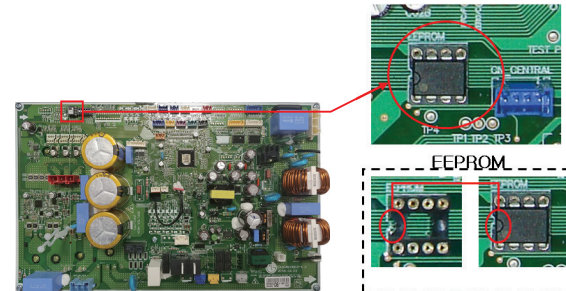

▶ 1Ø, 12kW / 14kW / 16kW

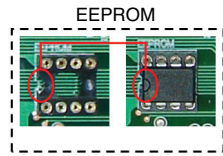

▶ 3Ø, 12kW / 14kW / 16kW

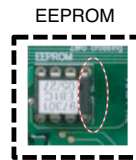
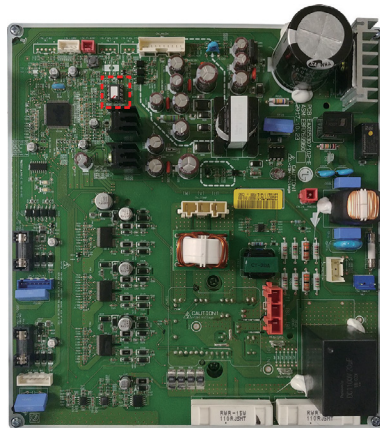

Error Code	Title	Cause of Error	Normal condition
61	High Pressure Error	<ul style="list-style-type: none"> Fan of outdoor unit is locked Condenser(Fin-tube) is polluted. Sensor or Outdoor PCB is self-defective. 	<ul style="list-style-type: none"> The pressure sensor is properly inserted into the Outdoor PCB.

Check Flow Chart (A)

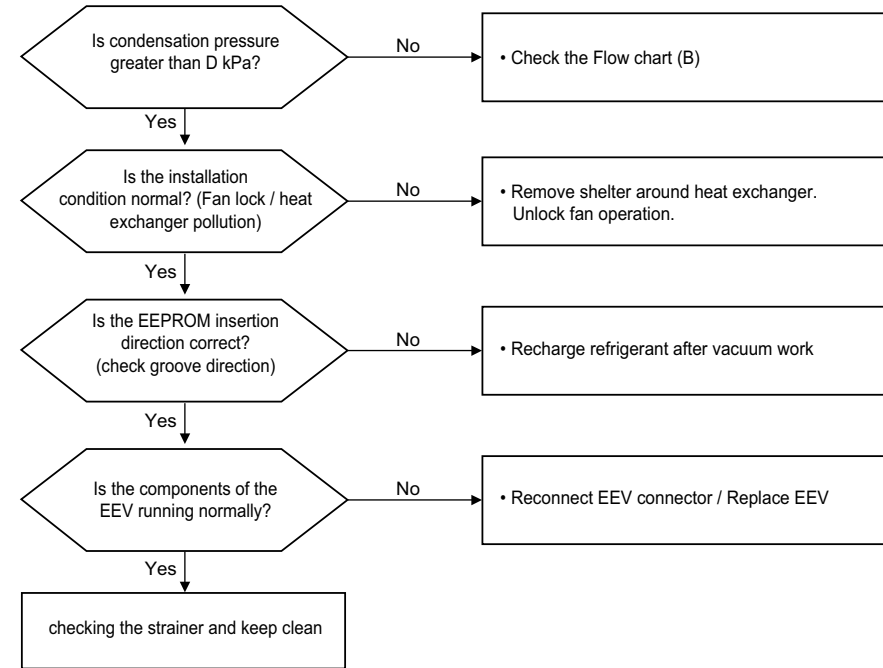

D kPa	AHUW096A3	ZHBW096A0
	AHUW076A3	ZHBW076A0
	AHUW056A3	ZHBW056A0
	AHUW168A3	ZHBW168A0
	AHUW166A3	ZHBW166A0
	AHUW148A3	ZHBW148A0
	AHUW146A3	ZHBW146A0
	AHUW128A3	ZHBW128A0
	AHUW126A3	ZHBW126A0
Cooling	4101	4199
Heating	4199	4199

Error Code	Title	Cause of Error	Normal condition
62	High Heatsink Temperature	<ul style="list-style-type: none"> • Temperature of heatsink is over 105 °C (Split) / 110 °C (Monobloc). • Inverter PCB is self-defective. • EEV operation is abnormal. • Pipe is clogging. 	<ul style="list-style-type: none"> • The sensor is properly inserted into the Inverter PCB.
65	Problem in Heatsink Temperature sensor		

Check Flow Chart (A)

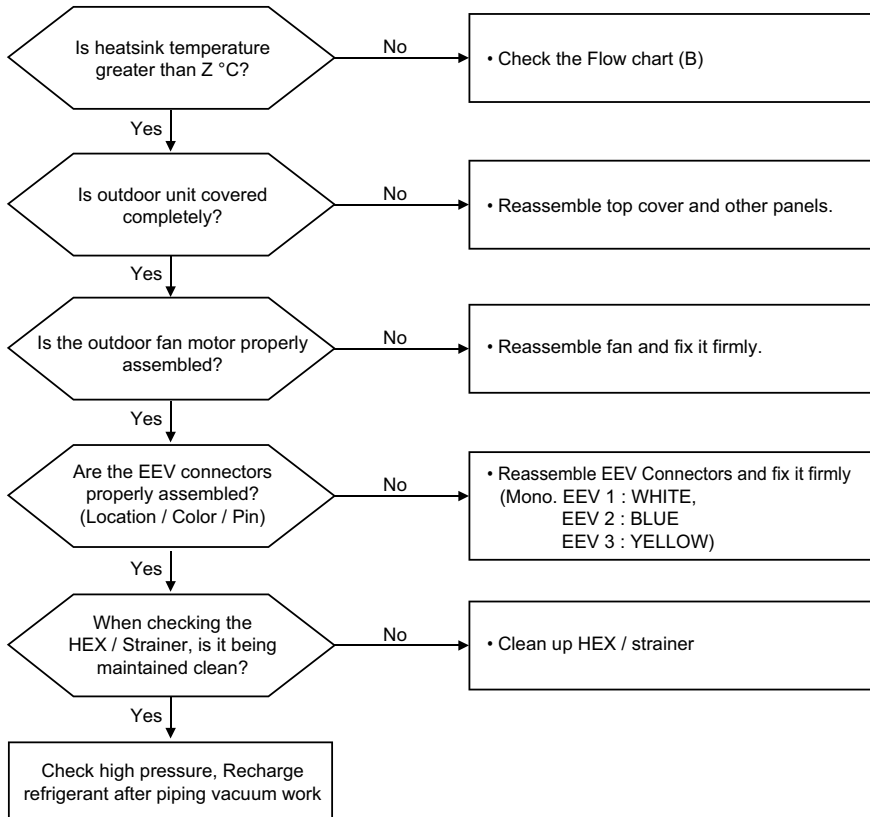

Model	Z °C
Split	105
Monobloc	110

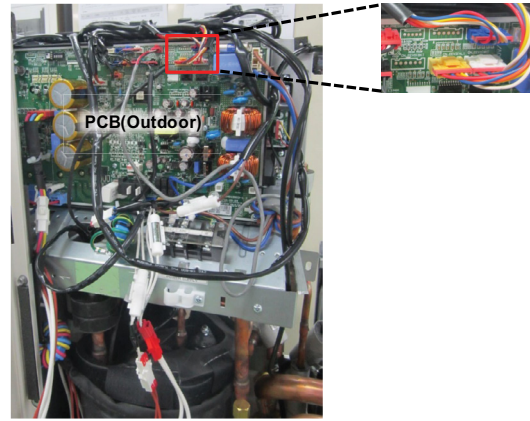

Check Point (CH62)

1. Check resistance between No.19 pin and NO.20 pin of PCB PFC module
2. Resistance value should be in 7 kΩ ±10 %.(at 25 °C).

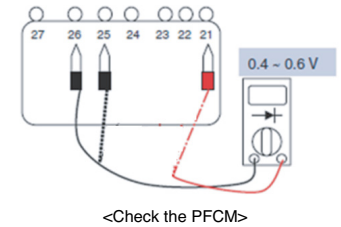
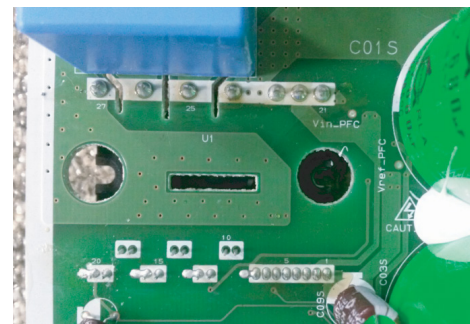

Check Flow Chart (B)

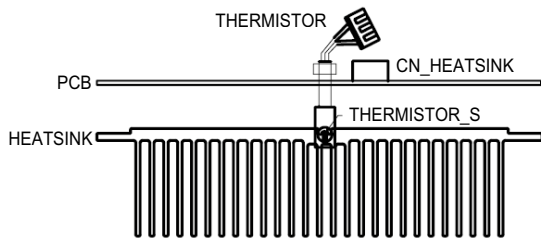
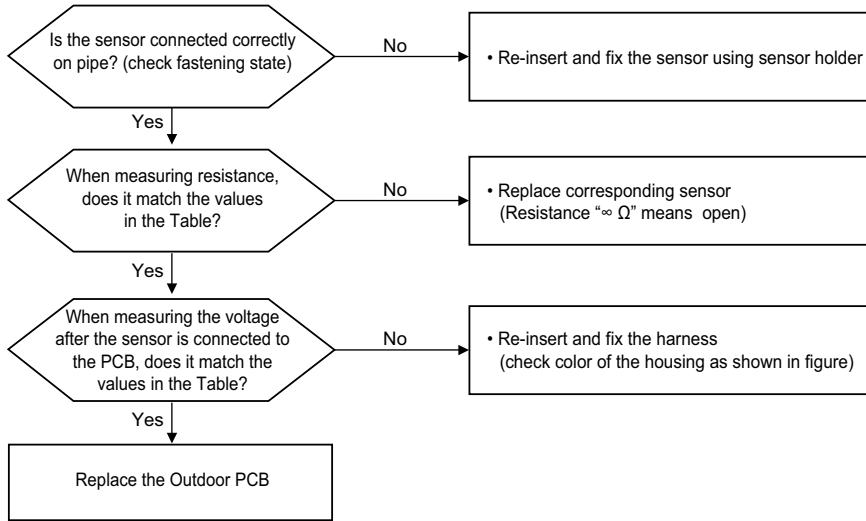

Error Code	Title	Cause of Error	Normal condition
67	Fan Lock Error	<ul style="list-style-type: none"> Revolutions Per Minute (RPM) is lower than 10 for 5 seconds after start-up Revolutions Per Minute (RPM) is lower than 40 in steady state. 	<ul style="list-style-type: none"> Wire is properly connected between the Inverter PCB and Motor PCB.

Check Flow Chart (A)

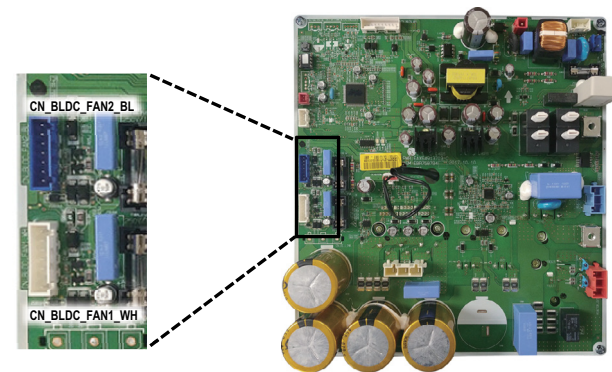
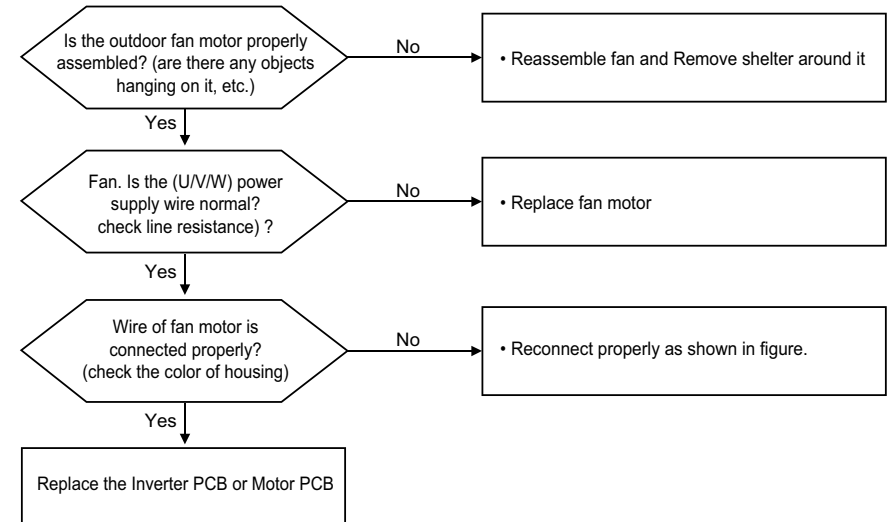

Check Point

▶ 1Ø, 5kW / 7kW / 9kW



Check voltage between 1pin and 4pin of fan motor

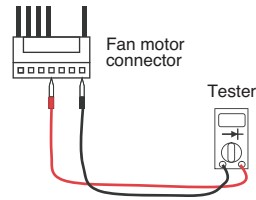

▶ 1Ø, 12kW / 14kW / 16kW

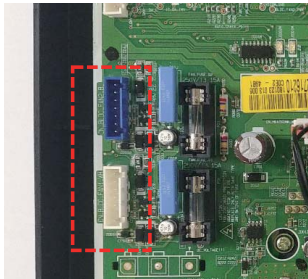
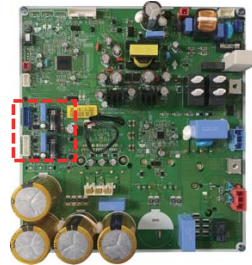

▶ 3Ø, 12kW / 14kW / 16kW

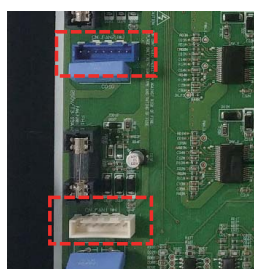

Pipe Temp

B Constant	3977	
Std Temp	25	
Resistance	5	
Temp	Resistance (kΩ)	Volt (V dc)
-30	102.17	4.714
-25	73.49	4.611
-20	53.55	4.481
-15	39.5	4.322
-10	29.48	4.131
-5	22.24	3.91
0	16.95	3.661
5	13.05	3.389
10	10.14	3.102
15	7.94	2.808
20	6.28	2.515
25	5	2.232
30	4.01	1.965
35	3.24	1.717
40	2.64	1.493
45	2.16	1.293
50	1.78	1.116
55	1.48	0.962
60	1.23	0.828
65	1.03	0.714
70	0.87	0.615
75	0.74	0.531
80	0.63	0.459
85	0.54	0.397
90	0.46	0.345
95	0.4	0.3
100	0.34	0.262

Air Temp

B Constant	3977	
Std Temp	25	
Resistance	10	
Temp	Resistance (kΩ)	Volt (V dc)
-30	204.35	4.72
-25	146.97	4.62
-20	107.09	4.492
-15	79	4.336
-10	58.95	4.149
-5	44.47	3.931
0	33.9	3.685
5	26.09	3.416
10	20.27	3.131
15	15.89	2.838
20	12.55	2.546
25	10	2.262
30	8.03	1.994
35	6.49	1.745
40	5.28	1.519
45	4.32	1.316
50	3.56	1.137
55	2.95	0.981
60	2.46	0.846
65	2.06	0.729
70	1.74	0.628
75	1.47	0.542
80	1.25	0.469
85	1.07	0.406
90	0.92	0.353
95	0.79	0.307
100	0.68	0.268

Heatsink Temp

B Constant	3970	
Std Temp	25	
Resistance	10	
Temp	Resistance (kΩ)	Volt (V dc)
-30	102.17	4.71
-25	73.49	4.61
-20	53.55	4.48
-15	39.5	4.32
-10	29.48	4.13
-5	22.24	3.91
0	16.95	3.66
5	26.05	4.73
10	20.25	4.66
15	15.87	4.57
20	12.55	4.47
25	10	4.35
30	8.03	4.21
35	6.49	4.06
40	5.28	3.89
45	4.33	3.71
50	3.57	3.52
55	2.96	3.32
60	2.47	3.11
65	2.07	2.9
70	1.74	2.69
75	1.48	2.48
80	1.26	2.28
85	1.07	2.09
90	0.92	1.9
95	0.8	1.73
100	0.69	1.57

D-Pipe Temp

B Constant	3500	
Std Temp	25	
Resistance	200	
Temp	Resistance (kΩ)	Volt (V dc)
-30	2845.99	4.969
0	585.66	4.851
5	465.17	4.814
10	372.49	4.77
15	300.58	4.717
20	244.33	4.657
25	200	4.587
30	164.79	4.508
35	136.64	4.418
40	113.98	4.318
45	95.62	4.208
50	80.65	4.088
55	68.38	3.958
60	58.27	3.82
65	49.88	3.674
70	42.9	3.522
75	37.05	3.365
80	32.14	3.205
85	27.99	3.043
90	24.46	2.88
95	21.46	2.719
100	18.89	2.561
110	14.79	2.255
120	11.72	1.972
130	9.4	1.716
140	7.62	1.487
150	6.24	1.287

How to check the insulation resistance between the compressor and panel

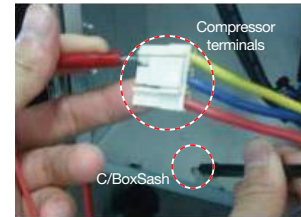

Measure the resistance between a compressor terminal and panel.

Terminal	Insulation Resistance
U-panel	$\geq 10\text{M}\Omega$
V-panel	$\geq 10\text{M}\Omega$
W-panel	$\geq 10\text{M}\Omega$

1. Turn the switch of the tester to "Resistance" mode and check the resistance
2. Measure the resistance between the terminals.
3. "0Ω" means the short of compressor phase. (Replace the compressor)
4. Refer to the compressor resistance standards.
5. If any disorder is found, measure the line resistance between the terminals of the compressor as shown below.
6. If the compressor is found to be normal, any compressor connection wire may have a fault.

How to check the U, V, and W phase resistance

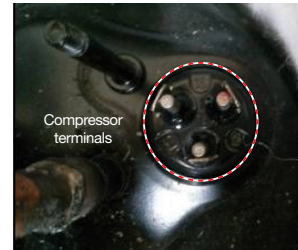

Measure the line resistance between the compressor terminals.

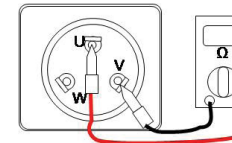

Model		RJB036MAA	GJT240MAA	GPT442MAA
Windings Resistance (at 25 °C)	U-V	0.529 ± 7 % Ω	0.628 ± 7 % Ω	0.724 ± 7 % Ω
	V-W	0.529 ± 7 % Ω	0.628 ± 7 % Ω	0.724 ± 7 % Ω
	W-U	0.529 ± 7 % Ω	0.628 ± 7 % Ω	0.724 ± 7 % Ω

IV. Function Control

1. Function List	116
2. Function Control Setting	120

1. Function List

Category	Functions	AHNW16606A3	AHNW16809A3
Installation	Drain pump	X	X
	E.S.P. control	X	X
	Electric heater	O	O
	High ceiling operation	X	X
	Auto Elevation Grille	X	X
Reliability	Hot start	X	X
	Self diagnosis	O	O
Convenience	Soft dry operation	X	X
	Auto changeover	X	X
	Auto cleaning	X	X
	Auto operation(artificial intelligence)	X	X
	Auto Restart	O	O
	Child lock	O	O
	Forced operation	X	X
	Group control	X	X
	Sleep mode	O	O
	Timer(on/off)	O	O
	Timer(weekly)	O	O
	Two thermistor control	X	X
	Standard Wired remote controller	O	O
	Deluxe wired remote controller	X	X
	Simple wired remote controller	X	X
Individual control	Simple Wired remote controller(for hotel use)	X	X
Network function	Wireless remote controller	X	X
	General central controller (Non LGAP)	X	X
	Network Solution(LGAP)	X	X
Special function kit	Dry contact	PDRYCB500	PDRYCB500
	PI 485(for Indoor Unit)	X	X
	Zone controller	X	X
Others	CTI(Communication transfer interface)	X	X
	Electronic thermostat	X	X
Air to Water Heat Pump Functions	Remote temperature sensor	PQRSTA0	PQRSTA0
	Group control wrie	X	X
	Telecom shelter controller	X	X
	Anti-condensation on floor(cooling)	O	O
	Water pump on / off Control	O	O
	Flow switch control	O	O
	Thermostat interface (230V AC)	O	O
	Thermostat interface (24V AC)	X	X
	DHW tank heating (Install kit)	PHLTA	PHLTC
	Solar-thermal interface with DHW tank (Solar thermal kit)	PHLLA	PHLLA
	PHEX anti-freezing control	O	O
	Water pump forced operation	O	O
	Autosetting according to ambient temperature	O	O
	Silent operation (with scheduler)	O	O
	Anti-overheating of water pipe	O	O
	Emergency operation	O	O
	Scheduler(DHW Tank Heating / DHW Tank Heater)	O	O
	Timer(DHW Tank Heating / DHW Tank Heater)	O	O
	Quick DHW tank Heating	O	O
	Electric Heater Capacity Control	O	O
	Screed drying mode	O	O
	Sump Heater	O	O
	Dry Contact (Main PCB)	O	O

Notes
 1. * : These functions need to connect the wired remote controller.
 O : Applied, X : Not applied

Accessory model name : Installed at field, ordered and purchased separately by the corresponding model name, supplied with separate package.

Category	Functions	AHNW16606A3	AHNW16809A3
Reliability	Defrost / Deicing	O	O
	High pressure switch	X	X
	Low pressure switch	X	X
	Phase protection	X	X
	Restart delay (3-minutes)	O	O
	Self diagnosis	O	O
Convenience	Soft start	X	X
	Test function	O	O
	Night Silent Operation	X	X
	Wiring Error Check	X	X
	Peak Control	X	X
	Mode Lock	X	X
Network function	Forced Cooling Operation (Outdoor Unit)	X	X
	Network solution(LGAP)	X	X

Notes
 1. * : These functions need to connect the wired remote controller.
 O : Applied, X : Not applied

Accessory model name : Installed at field, ordered and purchased separately by the corresponding model name, supplied with separate package.

Category	Functions	ZHBW056A0[HM051M U43] ZHBW076A0[HM071M U43] ZHBW096A0[HM091M U43]	ZHBW126A0 [HM121M U33] ZHBW146A0 [HM141M U33] ZHBW166A0 [HM161M U33]	ZHBW128A0 [HM123M U33] ZHBW148A0 [HM143M U33] ZHBW168A0 [HM163M U33]
Installation	Drain pump	X	X	X
	E.S.P control	X	X	X
	Electric heater (Install kit)	O (Accessory)	O (Accessory)	O (Accessory)
	High ceiling operation	X	X	X
	Auto Elevation Grille	X	X	X
Reliability	Hot start	X	X	X
	Self diagnosis	O	O	O
	Soft dry operation	X	X	X
Convenience	Auto Restart	O	O	O
	Child lock*	O	O	O
	Sleep mode	X	X	X
	Timer (on/off)	O	O	O
	Timer (weekly)*	O	O	O
	Two thermistor control	X	X	X
	Anti-condensation on floor (cooling)	O	O	O
	Water pump on / off Control	O	O	O
	Flow switch control	O	O	O
	Thermostat interface (230V AC)	O	O	O
Air to Water Heat Pump Functions	Thermostat interface (24V AC)	X	X	X
	DHW(Domestic Hot Water) Tank heater (Install kit)	O (Accessory)	O (Accessory)	O (Accessory)
	Solar thermal kit interface with DHW Tank	O (Accessory)	O (Accessory)	O (Accessory)
	PHEX anti-freezing control	O	O	O
	Water pump forced operation	O	O	O
	Autosetting according to ambient temperature	O	O	O
	Silent operation	O	O	O
	Anti-overheating of water pipe	O	O	O
	Emergency operation	O	O	O
	Weather Dependent Operation with Thermostat	O	O	O
	Scheduler (DHW Tank Heater)	O	O	O
	Timer (Domestic Hot Water Tank Heater)	O	O	O
	Quick Domestic Hot Water Tank Heating	O	O	O
	Electric Heater Capacity Control	O	O	O
	Screed Drying Mode	O	O	O
	Sump Heater	X	X	X
	Base Pan Heater	O	O	O
	Dry Contact (Main PCB)	O	O	O
	2 nd Circuit	O	O	O
	3 rd Party Boiler	O	O	O

Note

1. O : Applied, X : Not applied
 Accessory model name : Installed at field, ordered and purchased separately by the corresponding model name, supplied with separate package.

Refrigerant Side

Category	Functions	ZHBW056A0[HM051M U43] ZHBW076A0[HM071M U43] ZHBW096A0[HM091M U43]	ZHBW126A0 [HM121M U33] ZHBW146A0 [HM141M U33] ZHBW166A0 [HM161M U33]	ZHBW128A0 [HM123M U33] ZHBW148A0 [HM143M U33] ZHBW168A0 [HM163M U33]
Reliability	Defrost / Deicing	O	O	O
	High pressure switch	O	O	O
	Low pressure switch	X	X	X
	Phase protection	X	X	X
	Restart delay (3-minutes)	O	O	O
	Self diagnosis	O	O	O
Convenience	Soft start	X	X	X
	Test function	X	X	X
	Night Low Noise Operation	O	O	O
	Wiring Error Check	X	X	X
	Peak Control	X	X	X
	Mode Lock	O	O	O
Network function	Forced Cooling Operation (Outdoor Unit)	X	X	X
	Network solution(LGAP)	O	O	O

Note

1. O : Applied, X : Not applied
 Accessory model name : Installed at field, ordered and purchased separately by the corresponding model name, supplied with separate package.

Accessory Compatibility List

Category	Product	Remark	ZHBW056A0[HM051M U43] ZHBW076A0[HM071M U43] ZHBW096A0[HM091M U43] ZHBW126A0 [HM121M U33] ZHBW146A0 [HM141M U33] ZHBW166A0 [HM161M U33] ZHBW128A0 [HM123M U33] ZHBW148A0 [HM143M U33] ZHBW168A0 [HM163M U33]
Dry contact	Simple Contact	PDRYCB000	Simple Dry Contact
	Communication type	PDRYCB400	2 Points Dry Contact (For Setback)
		PDRYCB300	8 Point Dry Contact(For Thermostat)
		PDRYCB500	Dry Contact For Modbus
Gateway	IDU PI485	PHNFP14A0	Connected with the Indoor Units
ETC	Remote temperature sensor	PSNFP14A0	Connected with the Indoor Units
	Zone controller	PQRSTA0	-
	Electronic thermostat	ABZCA	-
	CTI (Communication transfer interface)	AQETC	-
	PKFC0	-	
	CO ₂ Sensor	PES-C0RV0	For ERV, ERV DX Indoor units
	Group control wire	PZCWRCG3	0.25m
	2-Remo Control Wire	PZCWRC2	0.25m
	Extension Wire	PZCWRC1	10m
	Wi-Fi Controller*	PWFMD200	-
Meter Interface	PENKTH000	Energy Check	
Accessory Kit for AWHP	Remote Controller Kit	-	For AWHP
	DHW Tank kit	PHLTB	-
	Solar Thermal kit	PHLLA / PHLLB	-
	Backup heater kit	AHEH066A / AHEH036A	-

Note

1. O: Possible, X: Impossible, - : Not applicable
 2. * : Some advanced functions controlled by individual controller cannot be operated.
 3. ** : It could not be operated some functions.
 4. If you need more detail, please refer to the BECON PDB or the manual of product.
 (<http://partner.lge.com/global> : Home-> Download-> Manuals)

2. Function Control Setting

DIP Switch Setting

CAUTION

- Turn off electric power supply before setting DIP switch
- Whenever adjusting DIP switch, turn off electric power supply to avoid electric shock.

General Information

Indoor PCB

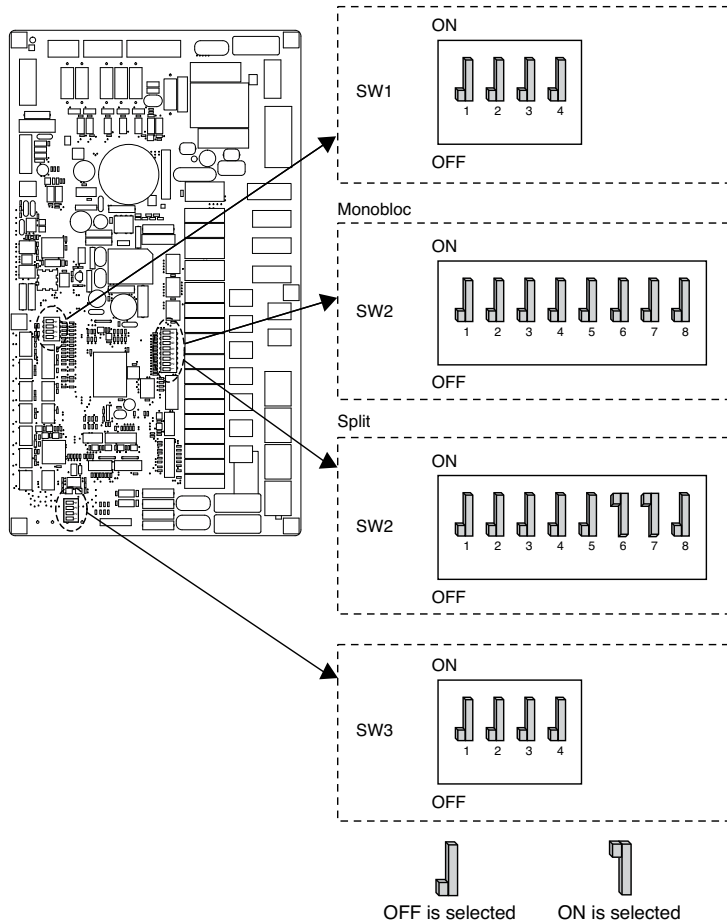













DIP Switch Information













Option Switch 2

Description	Setting	Default	
Role when central controller is equipped	1	As Master	1
	1	As Slave	
Accessory installation information	2 3	Unit + Outdoor unit is installed	2 3
	2 3	Unit + Outdoor unit + DHW tank is installed	
	2 3	Unit + Outdoor unit + DHW tank + Solar thermal system is installed	
	2 3	Reserved	
Cycle	4	Heating Only	4
	4	Heating & Cooling	
Flow Switch Detection	5	Always	5
	5	While water pump is on	
Selecting electric heater capacity	6 7	Electric heater is not used	6 7
	6 7	1Ø model : Half capacity is used 3Ø model : 1/3 capacity is used	
	6 7	Unused	
	6 7	Full capacity is used	
Thermostat installation information	8	Thermostat is NOT installed	8
	8	Thermostat is installed	

Option Switch 1

Description	Setting	Default
MODBUS	1  As Master	1 
	1  As Slave	
MODBUS Function	2  Common 3 rd party	2 
	2  SIEMENS	
Reserved	  3 3 Reserved	3 
Reserved	  4 4 Reserved	4 



Option Switch 3

Description	Setting	Default
Remote Air Sensor	1  Remote sensor is not installed	1 
	1  Remote sensor is installed	
ANTIFREEZE	2  Antifreeze mode not use	2 
	2  Antifreeze mode	
Reserved	  3 3 Reserved	3 
Reserved	  4 4 Not Use	4 

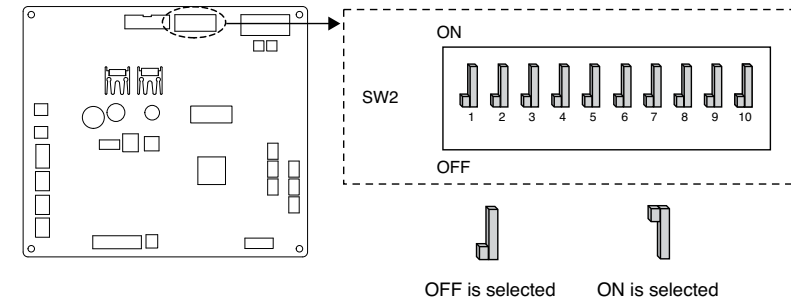
Outdoor PCB General Information



DIP Switch Information

Description	Setting	Default
Peak Control	3  Max Mode	3 
	3  Peak Control : To limit maximum current (Power saving)	

* Only DIP-switch no.3 has a function. Others have no function.

NOTE

* Input current value can be limited by DIP Switch operation.

Capacity	Mode	Max Mode Running Current(A)	Peak Control Mode Running Current(A)
1Ø 5,7,9kW	Cooling	23	17
	Heating	23	17
1Ø 12,14,16kW	Cooling	35	25
	Heating	35	27
3Ø 12,14,16kW	Cooling	15	10
	Heating	15	12

! NOTE**Emergency Operation****• Definition of terms**

- Trouble : a problem which can stop system operation, and can be resumed temporarily under limited operation without certificated professional's assist.
- Error : problem which can stop system operation, and can be resumed ONLY after certificated professional's check.
- Emergency mode : temporary heating operation while system met Trouble.

• Objective of introducing 'Trouble'

- Not like airconditioning product, Air-to-Water heat pump is generally operation in whole winter season without any system stopping.
- If system found some problem, which is not critical to system operating for yielding heating energy, the system can temporarily continue in emergency mode operation with end user's decision.

• Classified Trouble

- Trouble is classified two levels according to the seriousness of the problem : Slight Trouble and Heavy trouble
- Slight Trouble : a problem is found inside the unit. In most case, this trouble is concerned with sensor problems. The outdoor unit is operating under emergency mode operation condition which is configured by DIP switch No. 4 of the unit PCB.
- Heavy trouble : a problem is found inside the outdoor unit. As the outdoor unit has problem, the emergency mode operation is performed by electric heater located in the unit.
- Option Trouble : a problem is found for option operation such as water tank heating. In this trouble, the troubled option is assumed as if it is not installed at the system.

• When the AWHP has any trouble,

(1) If there is not a function to judge possibility of operation :

Once an error occurs mainly in indoor unit, AWHP stops. On the other hand, Remocon allows the product to activate On/ Off operation.(On : emergency operation)

- Slight / Heavy trouble : Heating Operable only
- Critical trouble : Full stop
- Treatment priority : Critical>Heavy>Slight

(2) If there is a function to judge possibility of operation :

Depending on the status of slight / heavy / critical trouble, pop-up phrase is guided separately on display.

- Slight trouble : Heating/Cooling Operable
- Heavy trouble : Heating Operable only
- Critical trouble : Service center request

AWHP operates when user pressed OK button on pop-up window.

! NOTE**• Duplicated trouble : Option trouble with slight or heavy trouble**

- If option trouble is occurred with slight (or heavy) trouble at the same time, the system puts higher priority to slight (or heavy) trouble and operates as if slight (or heavy) trouble is occurred.
- Therefore, sometimes DHW heating can be impossible in emergency operation mode. When DHW is not warming up while emergency operation, please check if DHW sensor and related wiring are all Ok.

• Emergency operation is not automatically restarted after main electricity power is reset.

- In normal condition, the product operating information is restored and automatically restarted after main electricity power is reset.
- But in emergency operation, automatic re-start is prohibited to protect the product.
- Therefore, user must restart the product after power reset when emergency operation has been running.

SERVICE SETTING

How to enter service setting

To enter the menu displayed at the bottom, you need to enter the service setting menu as follows.

- In the menu screen, press [←,→(left/right)] button to select the setting category, and press [OK] button to move to the setting list.
- In the setting list, select the service setting category, and press [OK] button to move to the service setting list.

Service setting

- You can set the product service functions.
- Some functions may not be displayed/operated in some product types.

Service Contact

Check and input the service center phone number that you can call when there is service issue.

- In the service setting list, select the service contact point and press [OK] button to move to the detail screen.
- While "edit" button is selected, press [OK] button to move to the edit screen, change it, and press [OK] button to change the service contact point.

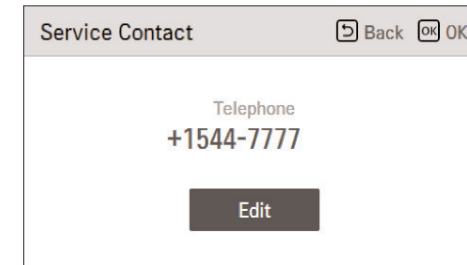
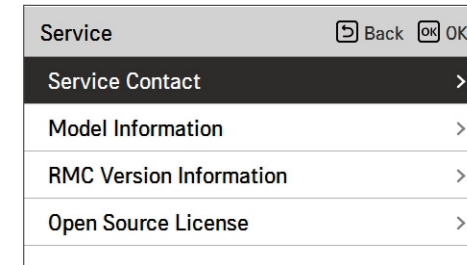

Model Information

Check product and capacity information to which the remote controller is connected.

- In the service setting list, select model information category, and press [OK] button to move to the detail screen.
- The unit capacity
 - $1\text{kWh} = 1\text{kBtu} * 0.29307$
 - kWh is the result calculated based on Btu, There may be a small difference between calculated and actual capacity.
 - Ex) If the unit capacity is 18kBtu, it is displayed as 5kWh.

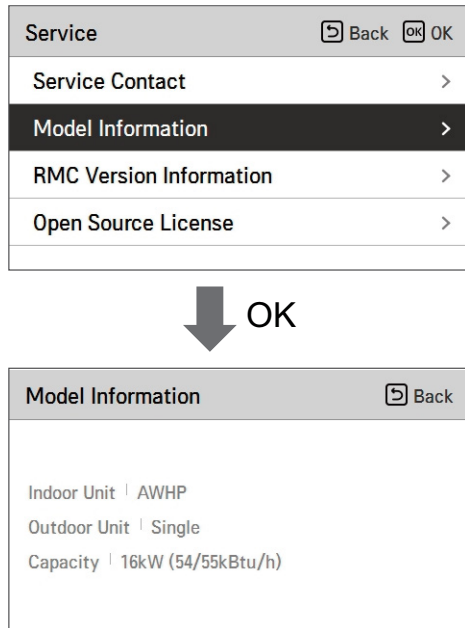

RMC Version Information

View the remote controller software version.

- In the service setting list, select the RMC version information and press [OK] button to move to the detail screen

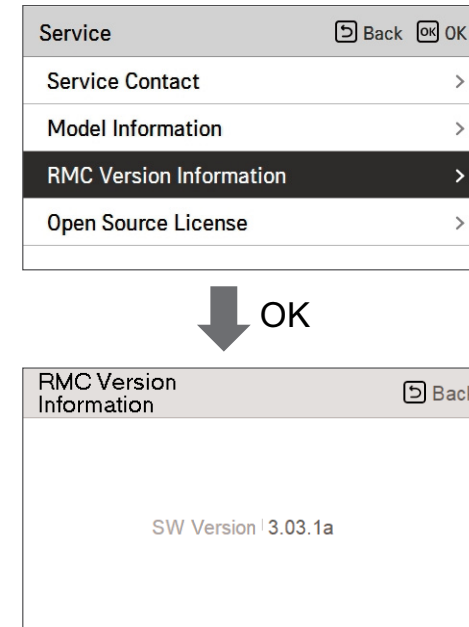

Open Source License

View the remote controller's open source license.

- In the service setting list, select the open source license category, and press [OK] button to move to the detail screen.

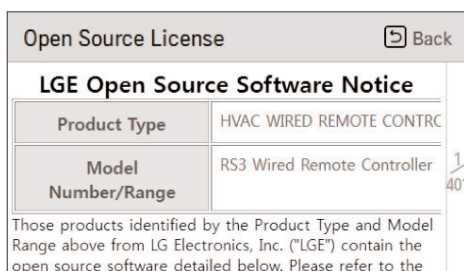
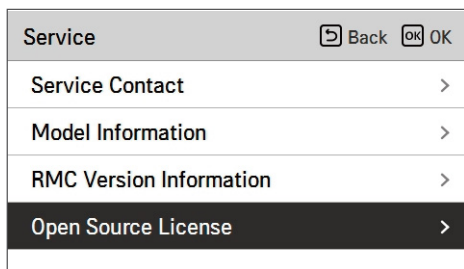

INSTALLER SETTING

How to enter installer setting

CAUTION

The installer setting mode is the mode to set the remote controller's detail function. If the installer setting mode is incorrectly set, it may cause product failure, user's injury, or property damage. It must be set by the installation specialist with the installation license, and if it is installed or changed without installation license, all problems caused will be the responsibility of the installer, and may void the LG warranty.

- In the menu screen, press [<, >] (left/right) button to select the setting category, and press [^] (up) button for 3 seconds to enter the password input screen for the installer setting.
- Input the password and press [OK] button to move to the installer setting list.

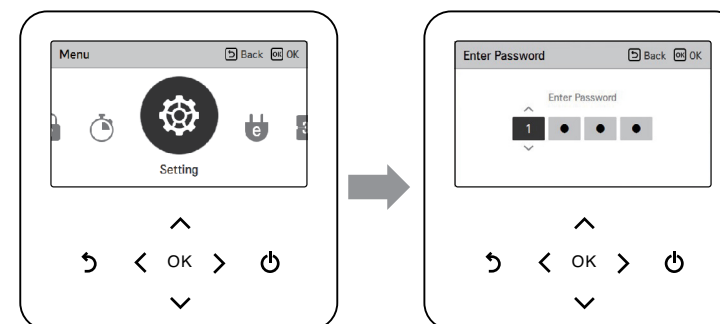

※ Installer setting password

Main screen → menu → setting → service → RMC version information → SW Version
 Example) SW version : 1.00.1 a
 In the above case, the password is 1001.

NOTE

Some categories of the installer setting menu may not be available depending on the product function or the menu name may be different.

Installer setting

- You can set the product user functions.
- Some functions may not be displayed/operated in some product types.

Function	Description
3 Minutes Delay	Factory use only
Select Temperature Sensor	Selection for setting temperature as air temperature or leaving water temperature or air+leaving water temperature
Dry Contact Mode setting	Dry contact function is the function that can be used only when the dry contact devices is separately purchased and installed.
Central Control address	When connecting the central control, set the central control address of the unit.
Pump Test run	Water pump test run
Air cooling set temp. setting	Adjusting range of 'Setting Air Temperature' in cooling mode
Water cooling set temp. setting	Adjusting range of 'Setting Leaving Water Temperature' in cooling mode
Air heating set temp. setting	Adjusting range of 'Setting Air Temperature' in heating mode
Water heating set temp. setting	Adjusting range of 'Setting Heating Flow Temperature' in heating mode
DHW Set Temp.setting	Setting DHW set temperature
Screed drying setting	Setting for using Step 1 or 2 capacity of electric
Heater on temperature	Setting outdoor air temperature where half capacity of electric heater starts operation.
Water supply off temp. during cooling setting	Determine leaving water temperature when the unit is turned off. This function is used for preventing condensation on the floor in cooling mode
Tank disinfection setting 1	Setting start/maintain time for pasteurisation
Tank disinfection setting 2	Setting pasteurisation temperature
Tank setting 1	Setting start temperature for operation
Tank setting 2	Setting maintain temperature for operation
Heater priority	Determine electric heater and water heater on and off
DHW time setting	Determine follow time duration : operation time of domestic hot water tank heating, stop time of domestic hot water tank heating, and delay time of DHW tank heater operating
TH on/off Variable, heating air setting	Heating air temperature TH On / Off Type setting
TH on/off Variable, heating Water setting	Heating Water Outlet Temperature TH On / Off Type

Function	Description
TH on/off Variable, cooling air setting	Cooling air temperature TH On / Off Type setting
TH on/off Variable, cooling Water setting	Cooling Water Outlet Temperature TH On / Off Type
Heating temp. setting	At the leaving water control in heating mode, the control reference water temperature position setting
Cooling temp. setting	At the leaving water control in cooling mode, the control reference water temperature position setting
Pump setting in heating	Set water pump on / off delay option in heating mode
Pump setting in cooling	Set water pump on / off delay option in cooling mode
Forced operation	Water pump off After 20 consecutive hours, disable / enable the logic that drives the water pump by itself
CN_CC setting	It is the function to set whether to install (use) Dry Contact. (It is not a function for Dry Contact installation, but it is a function to set the usage of the unit's CN_CC port.)
Pump Capacity	Function to change Water Pump Capacity
Smart Grid(SG) setting	Select whether to use or not use the SG Mode function of the product, set the operation option value in SG1 step.
Seasonal auto temp setting	Set the operating temperature in Seasonal Auto mode
Modbus Address	It is function to set the address of the Modbus device that is externally linked to the product. Modbus address setting function is available from indoor unit.
CN_EXT	Function to set external input and output control according to DI / DO set by customer using dry contact port of indoor unit. Determine the use of the contact port (CN_EXT) mounted on the indoor unit PCB
Anti-freezing Temperature	This function prevents the product from freezing.
Add Zone	Install additional valve in product to control additional operation area
Use External Pump	Set up to control an external water pump
3rd Party Boiler	Configuration to control 3rd party boiler
Meter Interface	When installing the meter interface to measure energy / calorie in the product, set unit spec for each port
Pump Prerun/Overrun	Set to reach the optimum flow rate by circulating the heating water with the water pump before heat exchange. After the operation stop, additional water pump is activated to circulate the heating water.
Data logging setting	Display error history of connected unit
Password Initialization setting	It is the function to initialize (0000) the password when you forgot the password set in the remote controller.

3 Minutes Delay

Temporarily eliminates the 3-minute delay function of the outdoor unit Comp

- Factory use only
- In the installer setting list, select 3 Minutes Delay category, and press [OK] button to move to the detail screen.

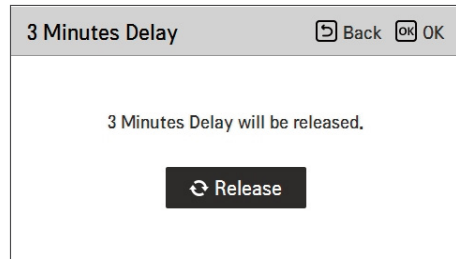
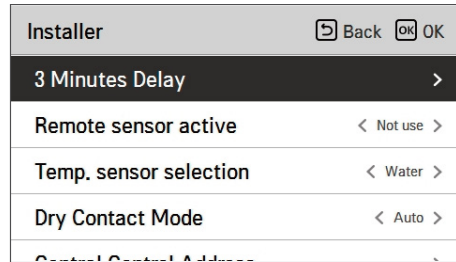

Select Temperature Sensor

The product can be operated according to air temperature or leaving water temperature. The selection for setting temperature as air temperature or leaving water temperature is determined.

- In the installer setting list, Select Temperature Sensor category, and press [OK] button to move to the detail screen.

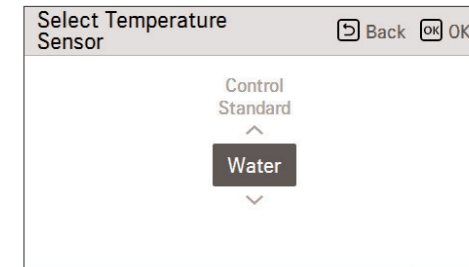
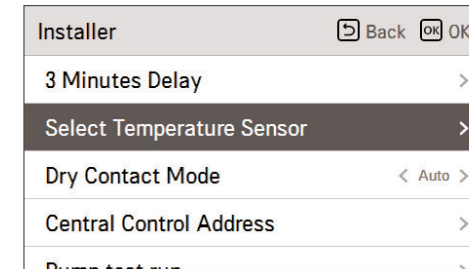

Value		
Water	Air	Air+Water

! NOTE

Air temperature as setting temperature is ONLY available when Remote Air Sensor Connection is enabled and Remote Air Sensor Connection is set as 02.

Dry Contact Mode

Dry contact function is the function that can be used only when the dry contact devices is separately purchased and installed.

- Change setting values using [<, > (left/right)] button.

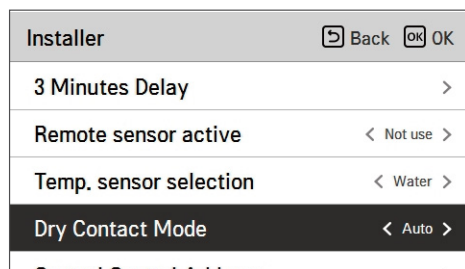

Value
Auto
manual

! NOTE

For dry contact mode related detail functions, refer to the individual dry contact manual.

What is dry contact?

It means the contact point signal input when the hotel card key, human body detection sensor, etc. are interfacing with the air conditioner.

Added system functionality by using external inputs (dry contacts and wet contacts).

Central Control Address

When connecting the central control, set the central control address of the unit.

- In the installer setting list, select Central Control Address category, and press [OK] button to move to the detail screen.

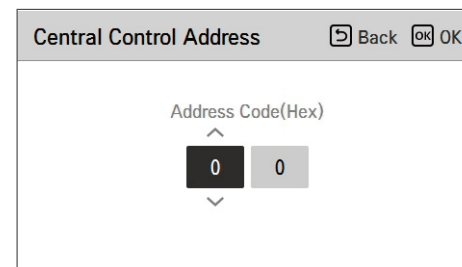
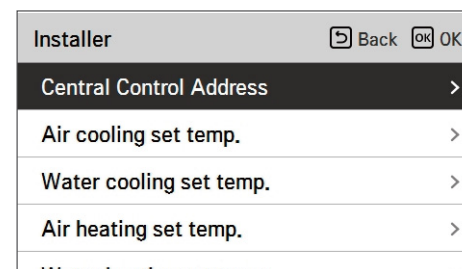

! NOTE

Enter address code as hexadecimal value

Front: Central Control Gr. No.

Back side: Central control indoor the number

! NOTE

This function is not available for monobloc

Pump test run

The pump test run is the function to test run by operating the water pump. This function can be used for air vents / flow sensors and others.

- In the installer setting list, Pump Test run category, and press [OK] button to move to the detail screen.

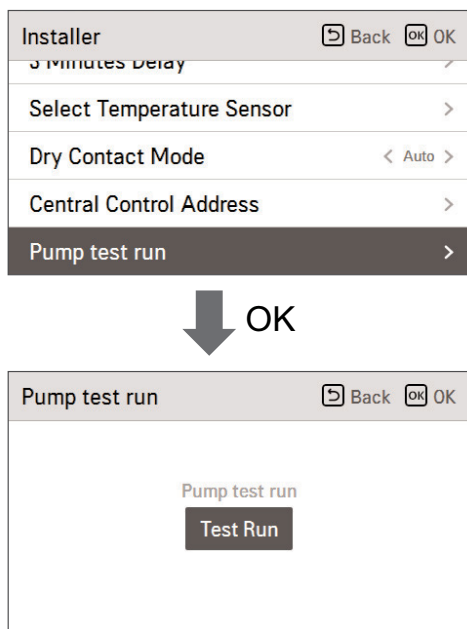

Air cooling set temp.

Determine cooling setting temperature range when air temperature is selected as setting temperature.

- In the installer setting list, select Air cooling set temp category, and press [OK] button to move to the detail screen.

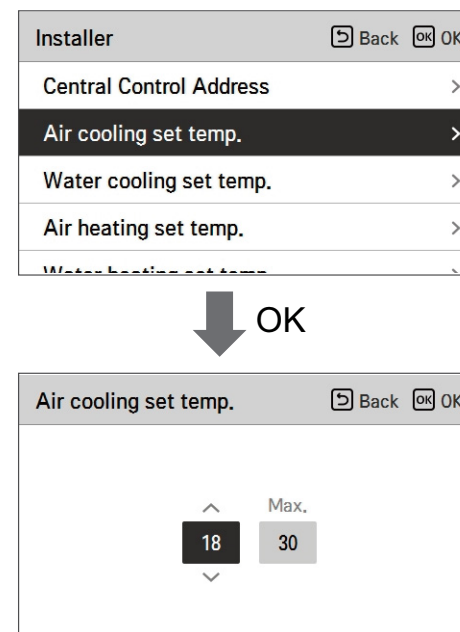

Value	Default	Range
Max.	30	30~24
Min.	18	22~16

* Upper / lower limit / default value is in °C

! NOTE

Only available when remote air temperature sensor is connected.

- Accessory PQRSTA0 should be installed.
- Also, Remote air sensor connection should be set properly.

Water cooling set temp

Determine cooling setting temperature range when leaving water temperature is selected as setting temperature.

- In the installer setting list, select water cooling set temp category, and press [OK] button to move to the detail screen.

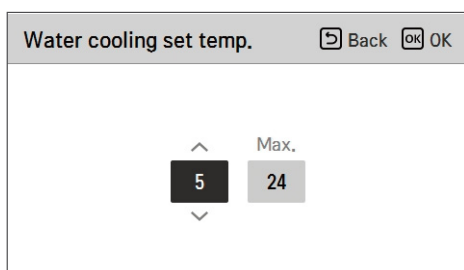
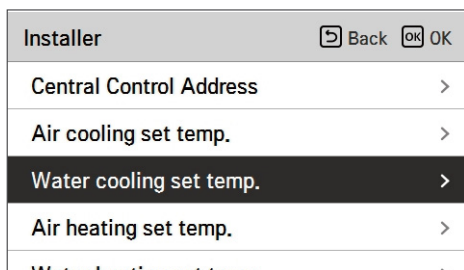

Value	Default	Range
Max.	24	27~22
Min.	18	20~5

* Upper / lower limit / default value is in °C

NOTE

Water condensation on the floor

- While cooling operation, it is very important to keep leaving water temperature higher than 16 °C. Otherwise, dew condensation can be occurred on the floor.
- If floor is in humid environment, do not set leaving water temperature below 18 °C.

NOTE

Water condensation on the radiator

- While cooling operation, cold water may not flow to the radiator. If cold water enters to the radiator, dew generation on the surface of the radiator can be occurred.

Air heating set temp.

Determine heating setting temperature range when air temperature is selected as setting temperature

- In the installer setting list, select Air heating set temp. category, and press [OK] button to move to the detail screen.

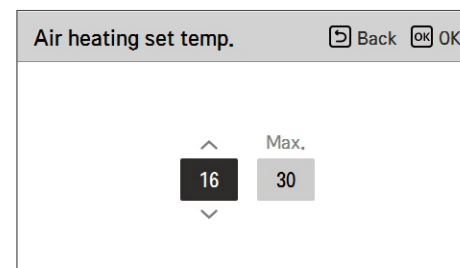
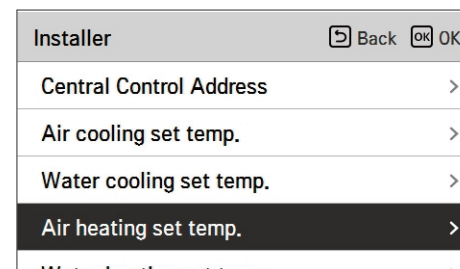

Value	Default	Range
Max.	30	30~24
Min.	16	22~16

* Upper / lower limit / default value is in °C

CAUTION

- Only available when remote air temperature sensor is connected.
- Accessory PQRSTA0 should be installed.
- Also, Remote air sensor connection should be set properly.

Water heating set temp

Determine heating setting temperature range when leaving water temperature is selected as setting temperature

- In the installer setting list, select Water heating set temp. category, and press [OK] button to move to the detail screen.

Installer [Back] [OK]

- Central Control Address ✓
- Air cooling set temp. >
- Water cooling set temp. >
- Air heating set temp. >
- Water heating set temp. >**



Water heating set temp. [Back] [OK]

15 Max. 65

Value	Default	Range
Max.	65	65~35
Min.	15	34~15

* Upper / lower limit / default value is in °C

! NOTE

- When the E/heater is not used, the minimum temperature of the water temperature can be set from 34 °C to 20 °C

DHW set temp

Determine heating setting temperature range when DHW temperature is selected as setting temperature

- In the installer setting list, select DHW set temp. category, and press [OK] button to move to the detail screen.

Installer [Back] [OK]

- DHW set temp. >**
- Screed drying >
- Heater on temperature >
- Water supply off temp. during cooling >
- Task disinfection setting 1 >



DHW set temp. [Back] [OK]

40 Max. 50

Value	Range
Max.	80~50
Min.	40~30

* Upper / lower limit / default value is in °C

Screed drying

This function is a unique feature of AWP that, when AWP is installed in a new concrete structure, controls the specific temperature floor heating out temperature for a certain period of time to cure the floor cement.

- In the installer setting list, select Screed drying category, and press [OK] button to move to the detail screen.

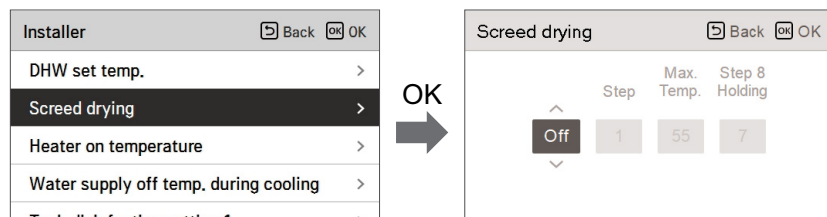

How to display

Main Screen - Displays 'Screed drying' on the desired temperature display. The step in progress at the bottom of the display is displayed.

Setting value

- Start-up step: 1 ~ 11
- Maximum temperature : 35 °C ~ 55 °C
- Step 8 Holding time : 1 days ~ 30 days

Function operation

- It is performed by the following procedure from the selected starting step.
- After all steps are completed, turn off the cement curing operation.

Step	1	2	3	4	5	6	7	8	9	10	11
Leaving Water target temperature[°C]	25	Max.T	Off	25	35	45	Max.T	Max.T	45	35	25
Duration [hours]	72	96	72	24	24	24	24	Holding time	72	72	72

- ※ If the upper limit setting value of the heating LW temperature is 55 °C or lower, it is set to 55 °C forcibly.
- If the lower limit setting value of the heating LW temperature is 25 °C or higher, it is set to 25 °C forcibly.

NOTE

- During Screed drying operation, button input except for installer function and temperature display is restricted.
- When the power is applied again after a power outage during product operation, the product operation state before power failure is remembered and the product is automatically operated.
- Screed drying operation stops when an error occurs / When error is cleared, restart cement Screed drying. (However, if the wired remote control is reset to the error occurrence state, it is compensated in the unit of one day)
- Upon releasing after an error, Screed drying operation may take up to 1 minute of waiting time after boot up. (The Screed drying operation status is judged as 1 minute cycle.)
- During Screed drying operation, installer function Screed drying operation is selectable.
- During Screed drying operation, starting operation, low noise mode off, low noise time setting off, hot water off, solar heat off.
- During Screed drying operation, simple, sleep, on, off, weekly, holiday, heater does not execute reservation operation.

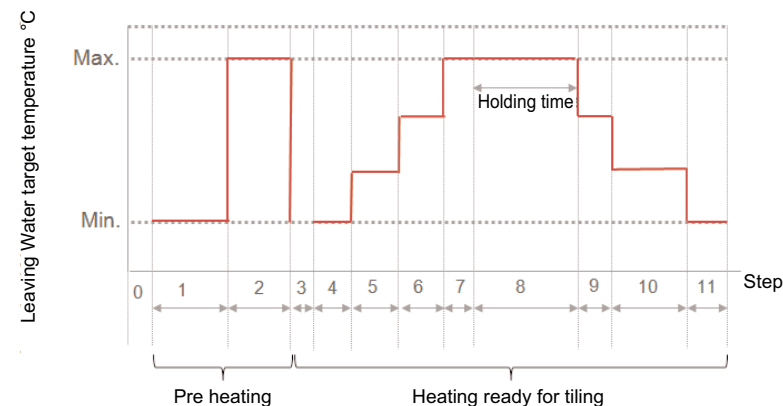

Heater on temperature

Depending on local climatic conditions, it is necessary to change the temperature condition in which electric heater turns on / off.

- In the installer setting list, Heater on temperature category, and press [OK] button to move to the detail screen.

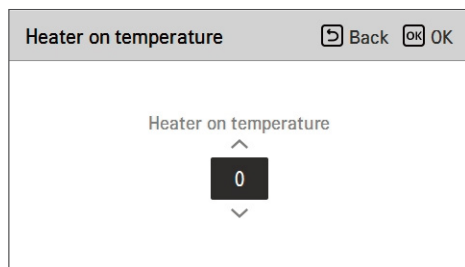
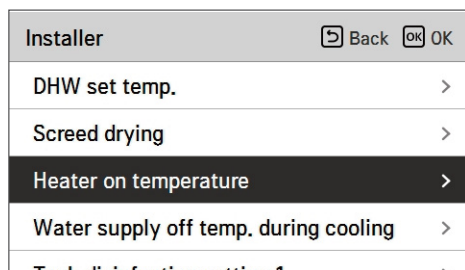

	Default	Range
Split	-5	18~-15
Mono	-5	18~-25

* Upper / lower limit / default value is in °C

NOTE

• Heater on temperature

Using Half capacity of electric heater : when DIP Switch No. 6 and 7 is set as 'OFF-ON' :

- Example : If Heater on temperature is set as '-1' and DIP switch No 6. and 7 is set as 'OFF-ON', then half capacity of electric heater will start operation when outdoor air temperature is below -1 °C and current leaving water temperature or room air temperature is much below than target leaving water temperature or target room air temperature.

Using Full capacity of electric heater : when DIP Switch No. 6 and 7 is set as 'OFF-OFF' :

- Example : If Heater on temperature is set as '-1' and DIP switch No 6. and 7 is set as 'OFF-OFF', then full capacity of electric heater will start operation when outdoor air temperature is below -1 °C and current leaving water temperature or room air temperature is much below than target leaving water temperature or target room air temperature.

Water supply off temp. during cooling

Determine leaving water temperature when the unit is turned off. This function is used for preventing condensation on the floor in cooling mode

- In the installer setting list, select Water supply off temp. during cooling category, and press [OK] button to move to the detail screen.

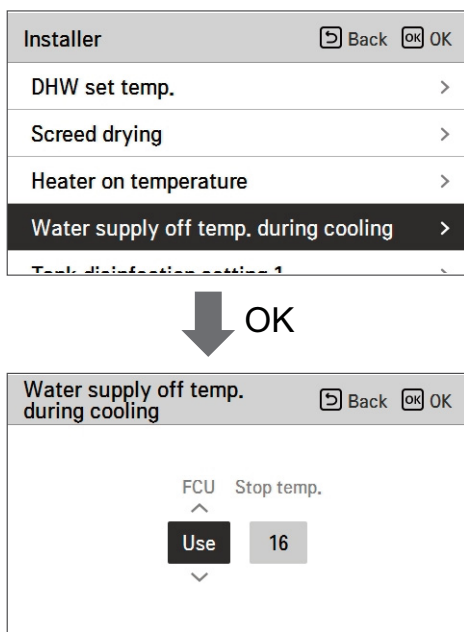

Function	Value	Default	Setting Rang
cooling water temperature	Water supply off temperature	16	25~16
	FCU Use/ not use	use	Use / Not Use

- Stop temp. : cut-off temperature. Stop temp. is valid when FCU is installed.
- FCU : determines if FCU is installed or not.
- Example : If Stop temp. is set as '10' and FCU is 'Use' and actually FCU is NOT installed in the water loop, the unit stop operation in cooling mode when the leaving water temperature is below 10 °C.
- Example : If Stop temp. is set as '10' and FCU is 'Not use' and actually FCU is installed in the water loop, the Stop temp. is not used and the unit do NOT stop operation in cooling mode when the leaving water temperature is below 10 °C.

CAUTION

FCU Installation

- If FCU is used, related 2way valve should be installed and connected to the unit PCB.
- If FCU is set as 'Not use' but FCU or 2way valve is NOT installed, the unit can do abnormal operation.

Tank disinfection setting 1, 2

- Disinfection operation is special DHW tank operation mode to kill and to prevent growth of viruses inside the tank.
 - Disinfection active : Selecting enable or disable of disinfection operation.
 - Start date : Determining the date when the disinfection mode is running.
 - Start time : Determining the time when the disinfection mode is running.
 - Max temp. : Target temperature of disinfection mode.
 - Duration time : Duration of disinfection mode.

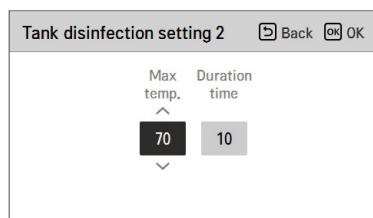
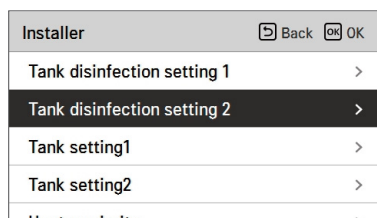
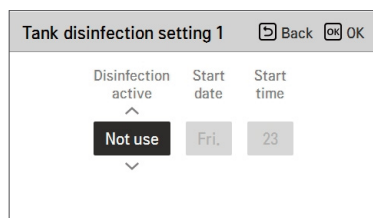
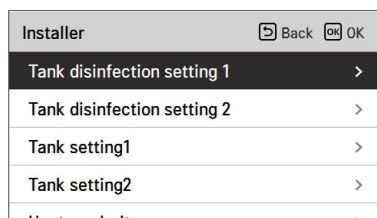
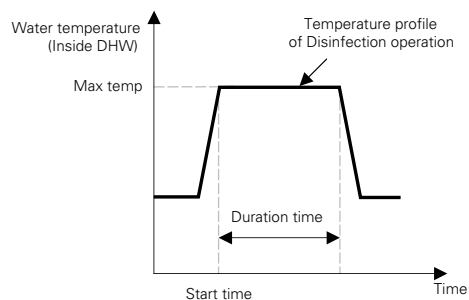

! NOTE

DHW heating should be enable

- If Disinfection active is set as 'Not use', that is 'disable disinfection mode', Start date and Start time is not used.

Tank setting 1

- In the installer setting list, select tank setting 1 category, and press [OK] button to move to the detail screen.

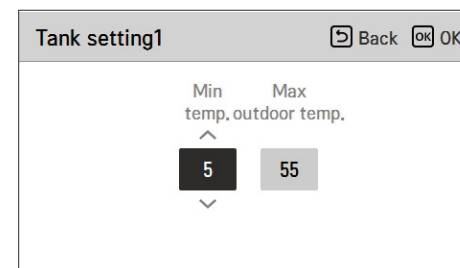
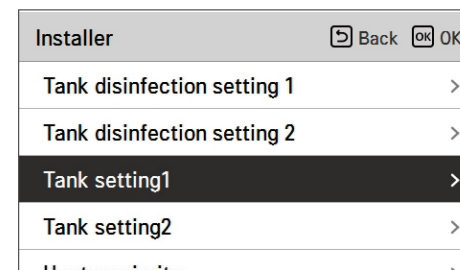

Value	Range
Max outdoor temp	55~40
Min temp	30~1

Tank setting 2

- In the installer setting list, select tank setting 2 category, and press [OK] button to move to the detail screen.

Installer	Back	OK
Tank disinfection setting 1	>	
Tank disinfection setting 2	>	
Tank setting1	>	
Tank setting2	>	
Hysteresis priority	>	



Tank setting2	Back	OK
Hysteresis	Heating priority	
3	DHW	

Value	Range
Hysteresis	4~2
Heating priority	Floor heating / DHW

• Tank setting 1, 2

Descriptions for each parameters are as following.

- Min temp. : temperature gap from Max outdoor temp.
- Max outdoor temp. : maximum temperature generated by AWHP compressor cycle.
- Example : If Min temp. is set as '5' and Max outdoor temp. is set as '48', then Session A (see the graph) will be started when the water tank temperature is below 45 °C.... If temperature is above 48 °C..., then Session B will be started.
- Hysteresis : temperature gap from target DHW temperature. This value is required to frequent On and Off of water tank heater.
- Heating priority : Determining heating demand priority between DHW tank heating and under floor heating.
- Example : If user's target temperature is set as '70' and Hysteresis is set as '3', then the water tank heater will be turned off when the water temperature is above 73 °C. The water tank heater will be turned on when the water temperature is below 70 °C.
- Example : If Heating priority is set as 'DHW', that means heating priority is on DHW heating, DHW is heated by AWHP compressor cycle and water heater. In this case the under floor can not be heated while DHW heating. On the other hand, if the Heating priority is set as 'Floor heating', that means heating priority is on under floor heating, DHW tank is ONLY heated by water heater. In this case the under floor heating is not stopped while DHW is heated.

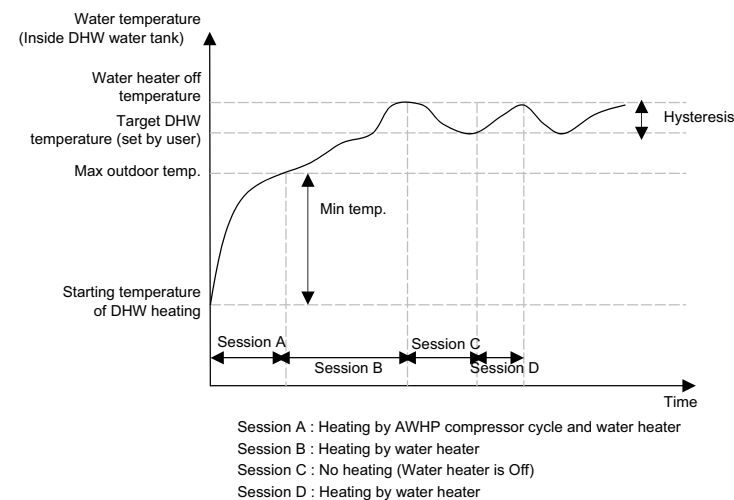

! NOTE

DHW heating does not operate when it is disabled.

Heater priority

- Heater priority : determine electric heater and DHW tank heater on and off.
- Example : If Heater priority is set as 'Main+Boost heater ON', then electric heater and DHW tank heater are on and off according to control logic. If Heater priority is set as 'Boost heater only ON', then electric heater is never turned on and only DHW tank heater is on and off according to control logic.
- In the installer setting list, heater priority category, and press [OK] button to move to the detail screen.

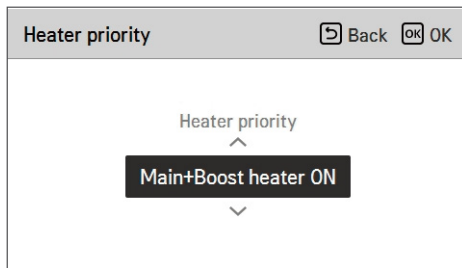
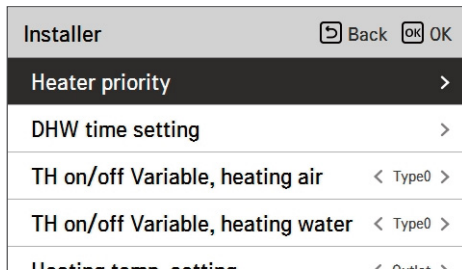

Value	
Boost heater only ON	Main+Boost heater ON

TH on/off Variable, heating air

It is a function to adjust the heating air temperature Thermal On / Off temperature according to the field environment in preparation for heating or heating claim.

- You can set the following setting values using [,<,>(left/right)] button.

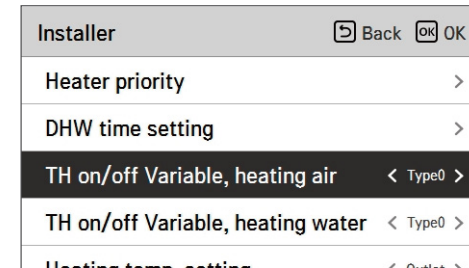

Value	Description	
	TH On	TH Off
Type0	-0.5 °C	1.5 °C
Type1	-1 °C	2 °C
Type2	-2 °C	3 °C
Type3	-3 °C	4 °C

TH on/off Variable, heating water

It is a function to adjust the heating water temperature Thermal On / Off temperature according to the field environment in preparation for heating or heating claim.

- You can set the following setting values using [<,>(left/right)] button.

Installer	Back	OK
Heater priority	>	
DHW time setting	>	
TH on/off Variable, heating air	< Type0 >	
TH on/off Variable, heating water	< Type0 >	
Heating temp. setting	< Type0 >	

Value	Description	
	TH On	TH Off
Type0	-2 °C	2 °C
Type1	-3 °C	3 °C
Type2	-4 °C	4 °C
Type3	-1 °C	1 °C

TH on/off Variable, cooling air

It is a function to adjust the cooling air temperature Thermal On / Off temperature according to the field environment in preparation for cooling or cooling claim.

- You can set the following setting values using [<,>(left/right)] button.

Installer	Back	OK
TH on/off Variable, heating air	< Type0 >	
TH on/off Variable, heating water	< Type0 >	
TH on/off Variable, cooling air	< Type0 >	
TH on/off Variable, cooling water	< Type0 >	
Pump setting in heating	>	

Value	Description	
	TH On	TH Off
Type0	0.5 °C	-0.5 °C
Type1	1 °C	-1 °C
Type2	2 °C	-2 °C
Type3	3 °C	-3 °C

TH on/off Variable, cooling water

It is a function to adjust the cooling water temperature Thermal On / Off temperature according to the field environment in preparation for cooling or cooling claim.

- You can set the following setting values using [<,>(left/right)] button.

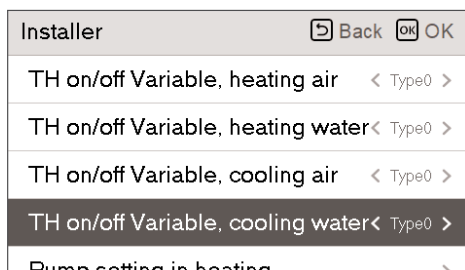

Value	Description	
	TH On	TH Off
Type0	0.5 °C	-0.5 °C
Type1	1 °C	-1 °C
Type2	2 °C	-2 °C
Type3	3 °C	-3 °C

Heating temp. setting

- At the leaving water control in heating mode, the control reference water temperature position setting
- If the air / leaving water temperature selection setting is set to leaving water temperature
- Change setting values using [<,>(left/right)] button

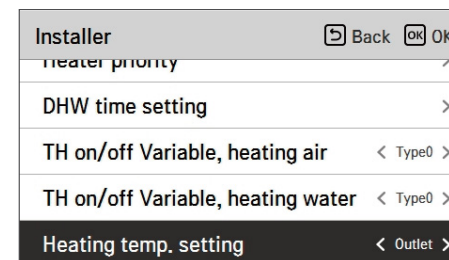

Value	
Outlet (Default)	Inlet

Cooling temp. setting

- At the leaving water control in cooling mode, the control reference water temperature position setting
- If the air / leaving water temperature selection setting is set to leaving water temperature
- Change setting values using [←,→(left/right)] button

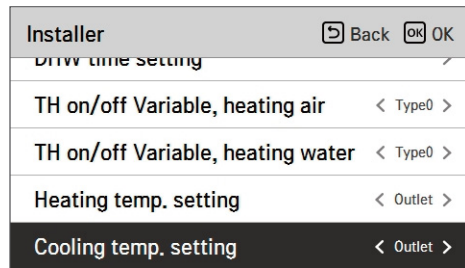

Value	
Outlet (Default)	Inlet

Pump setting in heating

- It is a function to help the water pump's mechanical life by putting the water pump's rest time
- Installer setting function to set water pump operation / delay time option in heating mode
- In the installer setting list, select Pump setting in heating category, and press [OK] button to move to the detail screen.

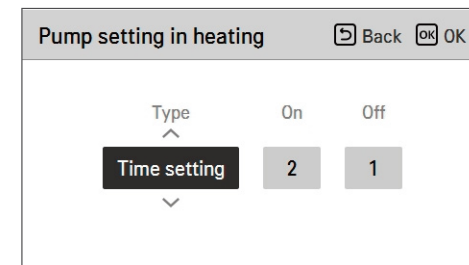
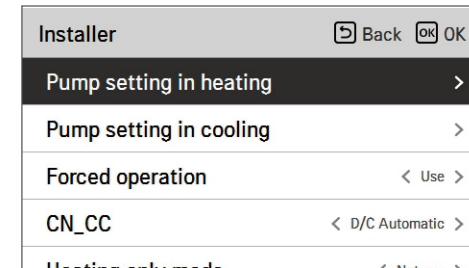

Type	Time setting	Operation continue
On	1 min ~ 60 min	-
Off	1 min ~ 60 min	-

Pump setting. in cooling

- It is a function to help the water pump's mechanical life by putting the water pump's rest time
- installer setting function to set water pump operation / delay time option in cooling mode
- In the installer setting list, select Pump setting in cooling category, and press [OK] button to move to the detail screen.

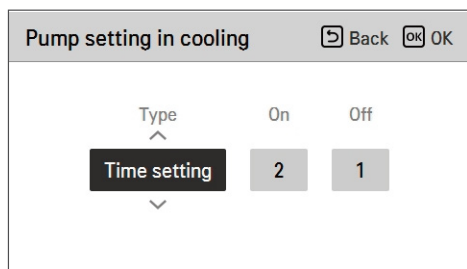
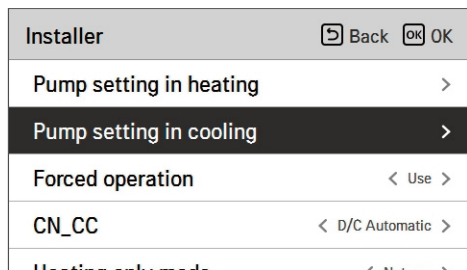

Type	Time setting	Operation continue
On	1 min ~ 60 min	-
Off	1 min ~ 60 min	-

Forced operation

- If the product is not used for a long time, the product will be forced to operate to prevent pump failure and PHEX freezing
- Water pump off After 20 consecutive hours, disable / enable the logic that drives the water pump by itself
- In the installer setting list, select Forced operation category, and press [OK] button to move to the detail screen

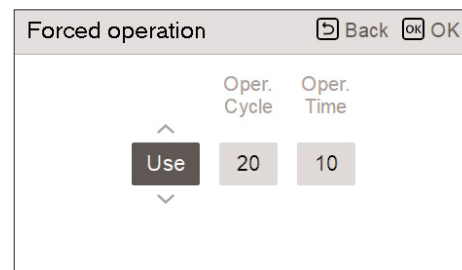
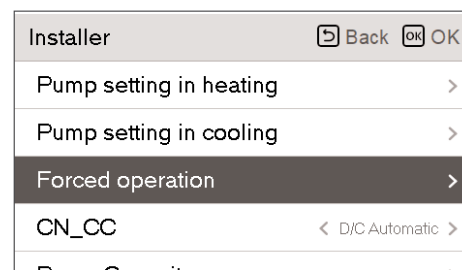

Type	Use	Not use
Oper. Cycle	20 min ~ 180 min	-
Oper. Time	1 min ~ 10 min	-

CN_CC

It is the function to set the usage of the unit's CN_CC port.

- Change setting values using [<, >] (left/right) button

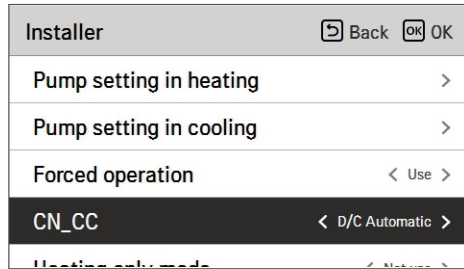

Value	Description
D/C Automatic	When power is applied to the product, the unit when the contact point is on in Dry Contact installed state recognizes Dry Contact installation
D/C Not Installed	Do not use (install) Dry Contact
D/C Installed	Use (install) Dry Contact

! NOTE

CN_CC is the device connected to the unit to recognize and control the external contact point.

Pump Capacity

It is a function to enable installer to control Pump capacity application model.

- In the installer setting list, select Pump Capacity category, and press [OK] button to move to the detail screen.

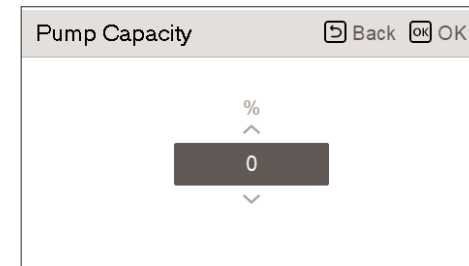
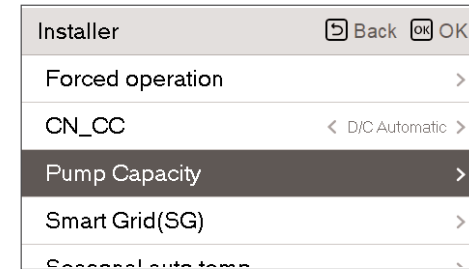

Value	Description
100 (Default)	10~100 : % Change unit: 5

Smart Grid(SG)

It is the function to enable / disable the SG Ready function and to set the reference value at SG2 step.

- In the installer setting list, select Smart Grid(SG) category, and press [OK] button to move to the detail screen.

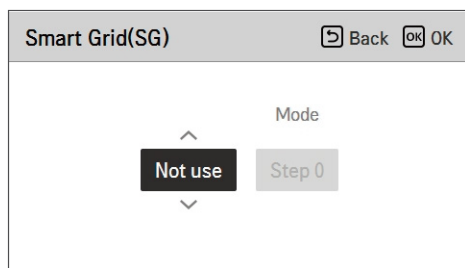
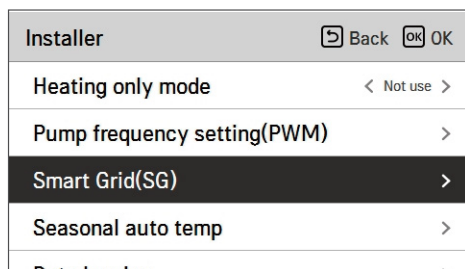

Value	Mode
Not use (Default)	-
Use	Step 0
	Step 1
	Step 2

Seasonal auto temp

It is the function to set the operation reference value in Seasonal Auto mode.

- In the installer setting list, select Seasonal auto temp category, and press [OK] button to move to the detail screen.

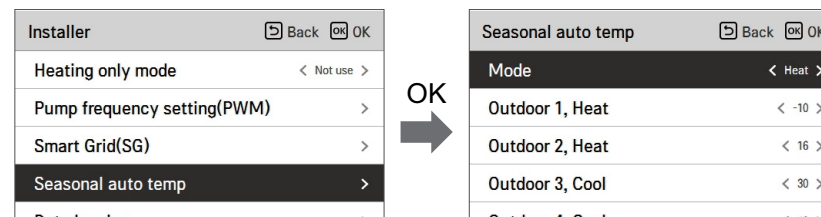

Setting	Description	Split 3	Split 3	Mono R32	Mono R32	Boundary
		Range	Default	Range	Default	
Out1	Heating lower outdoor temp	-15~24 °C	-10°C	-25~35 °C	-10 °C	Out1 ← Out2 - 1
Out2	Heating higher outdoor temp	-15~24 °C	16°C	-25~35 °C	16 °C	Out2 → Out1 + 1, Out2 ← Out3 - 5
Out3	Cooling lower outdoor temp	10~43 °C	30 °C	10~46 °C	30 °C	Out3 → Out2 + 5, Out3 ← Out4 - 1
Out4	Cooling higher outdoor temp	10~43 °C	40 °C	10~46 °C	40 °C	Out4 ← Out3 + 1,
LW1	Heating higher water temp	15~57 °C	35 °C	15~65 °C	35 °C	LW1 ← LW2
LW2	Heating lower water temp	15~57 °C	28 °C	15~65 °C	28 °C	LW2 → LW1
LW3	Cooling higher water temp	5~25 °C	20 °C	5~27 °C	20 °C	LW3 ← LW4
LW4	Cooling lower water temp	5~25 °C	16 °C	5~27 °C	18 °C	LW4 → LW3
Air1	Heating higher Air temp	16~30 °C	30 °C	16~30 °C	30 °C	Air1 ← Air2
Air2	Heating lower Air temp	16~30 °C	26 °C	16~30 °C	26 °C	Air2 → Air1
Air3	Cooling higher Air temp	18~30 °C	22 °C	16~30 °C	22 °C	Air3 ← Air4
Air4	Cooling lower Air temp	18~30 °C	18 °C	16~30 °C	18 °C	Air4 → Air3

- Setting range: Celsius

- Seasonal Auto Driving mode: Heating, Heating & Cooling, Air-conditioning

* If heating mode is selected, heating & cooling or cooling can not be selected.

- Depending on the air / outflow control selection value, the water / air related setting value is displayed on the screen.

In this mode, setting temperature will follow outdoor temperature automatically. This mode adds the cooling season function to the conventional weather dependent operation mode.

	Auto-Adjustable Target Temp.	Room Air Temp.(°C)	Leaving Water Temp.	Outdoor Air Temp.	
Heating	Set point 1	30~20	57~39	Set point 5	-20 ~ -10
	Set point 2	19~16	38~20	Set point 6	-5 ~ 5
Cooling	Set point 3	30~24	25~17	Set point 7	10 ~ 18
	Set point 4	23~18	16~6	Set point 8	22 ~ 30

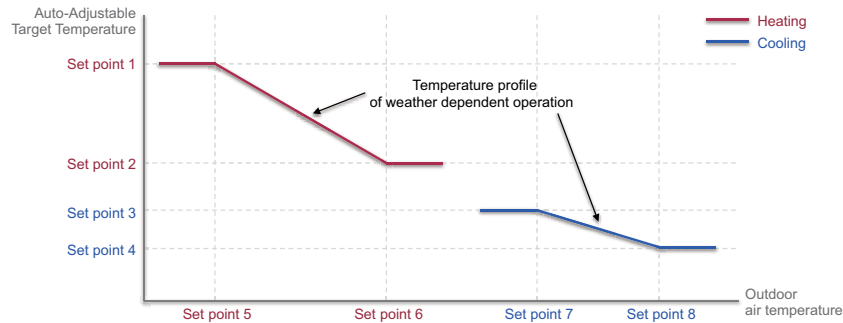

Modbus Address

It is function to set the address of the Modbus device that is externally linked to the product. Modbus address setting function is available from indoor unit.

- In the installer setting list, select Modbus Address , and press [OK] button to move to the detail screen.

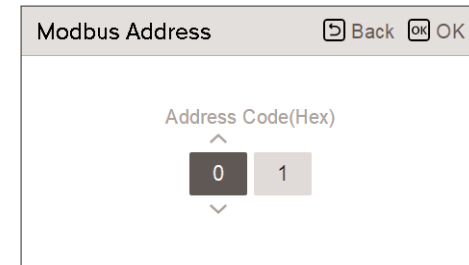
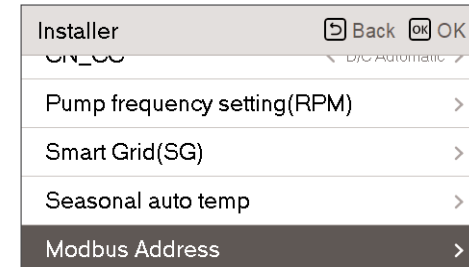

NOTE

To use this function, switch No.1 of option switch 1 must be turned ON.

CN_EXT

It is a function to control external input and output according to DI type set by customer using CN-EXT Port.

- In the installer setting list, select CN-EXT Port category, and press [OK] button to move to the detail screen.

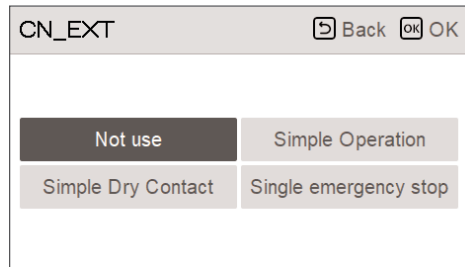
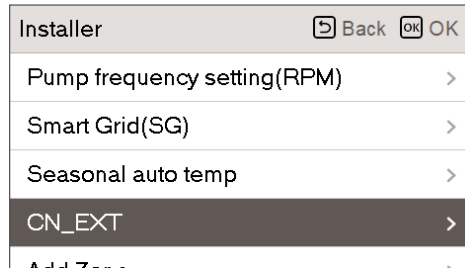

Value			
Not use	Simple Operation	Simple Dry Contact	Single emergency stop

Anti-freezing Temperature

Anti-freeze temperature setting is available in installer mode. It prevents frostbite from happening In the range of -25 to -5 degree celsius.

- Change setting values using [<, >(left/right)] button

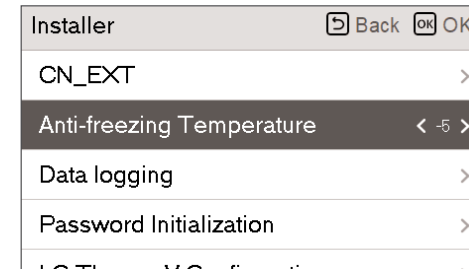

! NOTE

To use this function, the antifreeze short pin must be open and switch No.2 in Option SW 3 must be on.

Add Zone

Function to set whether or not to use a installed 2nd circuit function using mixing kit.

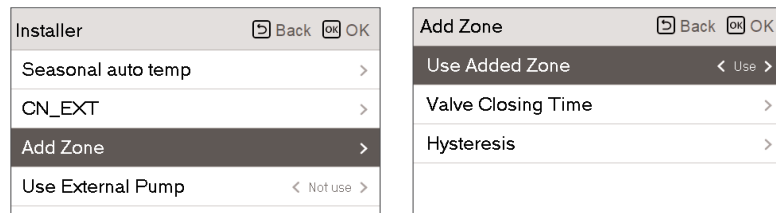

You can set valve closing time[sec] and hysteresis temperature[°C] on screen by yourself.

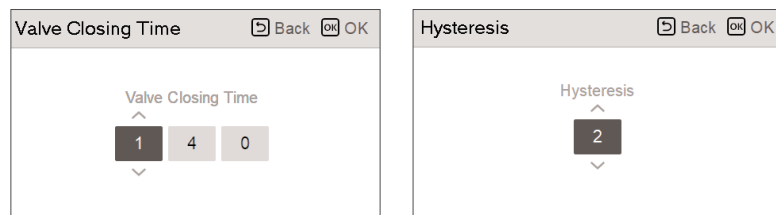

Activating this function, It allows 2 zones(Room1, Room2) temperature to be controlled, separately.

- In case of heating, the temperature of Room1 can not be set higher than Room2 temperature.
- In case of cooling, the temperature of Room1 can not be set lower than Room2 temperature.

Setting range

- Add Zone (2nd Circuit function setting) : Use / Not Use
- Value Closing Time : 60 ~ 999 sec (Default: 240)
- Hysteresis (Thermal On / Off) : 1 ~ 5 °C (Default: 2)

Use External Pump

This function can be set to control the external water pump.

- In the installer setting list, select Use External Pump category, and press [OK] button to move to the detail screen.

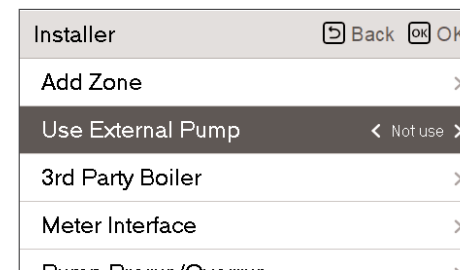

Value	
Not use	Use

3rd Party Boiler

This function is to configure the 3rd party boiler to be controlled.

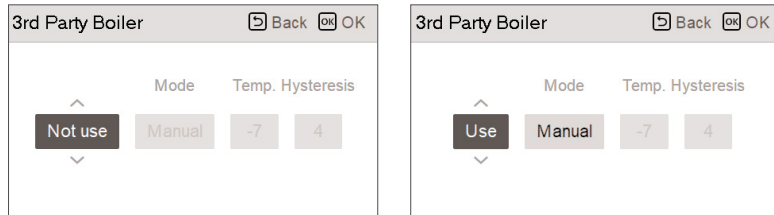

If the status of this function is "Use", you can choose control mode of boiler, Auto or Manual.

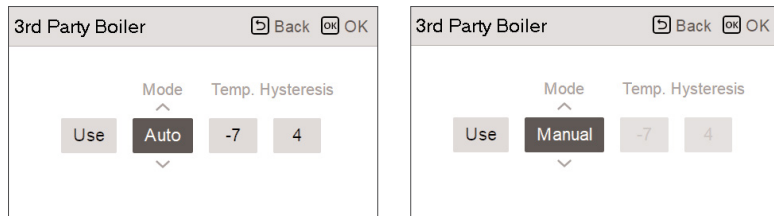

If the mode of this function is set to "Manual", you can set temperature of the boiler and hysteresis, respectively.

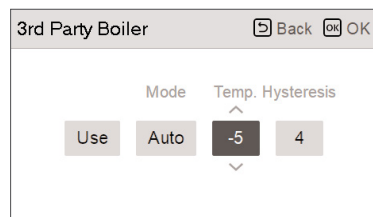

External boiler ON condition :

- If outdoor temperature \leq external boiler operation temperature value (installer setting), turn off the indoor unit and operate the external boiler.

External boiler OFF condition :

- If External air temperature \geq external boiler operation temperature value (installer setting) + Hysteresis (installer setting), turn off external boiler operation and operate indoor unit

Meter Interface

It is the function that can check the status of energy and power on screen. It collects and calculates power or calorie data to create data for energy monitoring and energy warning alarm pop-ups. This function can be activated in installer mode.

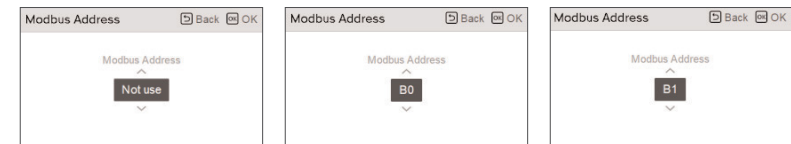
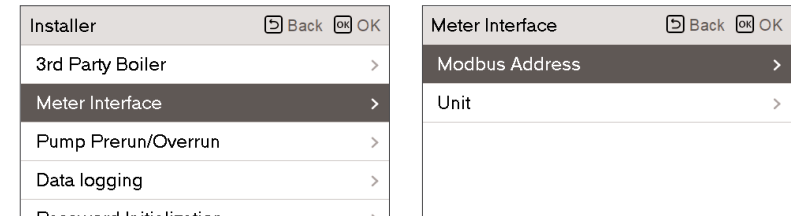

There are 2 options, modbus address and unit, in this function. Activating the modbus address option, you choose one address(B0 or B1) or don't use. Then, you set the port and specification in range of 0000.0~9999.9[pulse/kWh] as shown in the figure below.

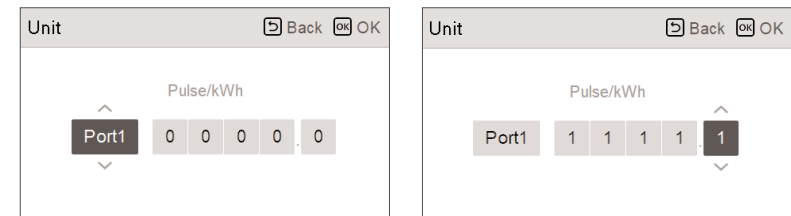

Pump Prerun/Overrun

Pump Prerun operates to ensure sufficient flow before the compressor is operated. This is a function that allows heat exchange to work smoothly.

Pump Overrun is a function to prevent water pump failure and to help mechanical life. If the water pump has been off for 20 hours, Water pump will operate for the set time

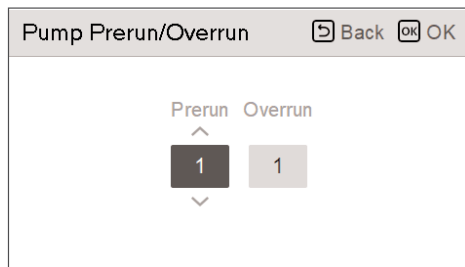
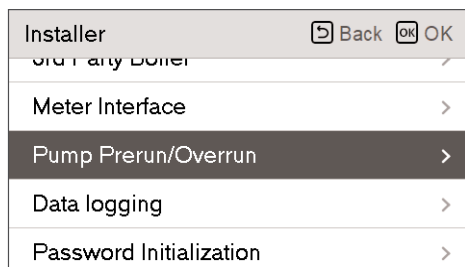

Value	Default	Setting Range
Prerun	1 min	1~10 min
Overrun	10 min	1~10 min

Data logging

It is the function to set the operation reference value in Seasonal Auto mode.

- In the installer setting list, select Data logging category, and press [OK] button to move to the detail screen.

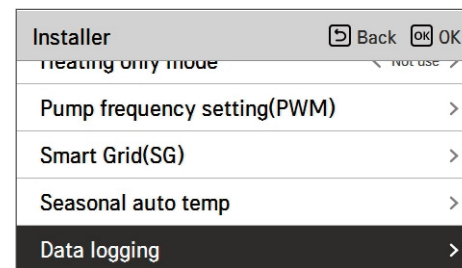

The screenshot shows the 'Data logging' detail screen with a 'Back' button at the top right. It displays a table of logged events with columns for Date, Time, Oper., Settemp, and In/Out.

Date	Time	Oper.	Settemp	In/Out
1970.01.01	00:10	Off	-	24° / 25°
1970.01.01	00:09	Off	-	24° / 25°
1970.01.01	00:09	Off	-	24° / 25°
1970.01.01	00:09	Off	-	24° / 25°
1970.01.01	00:09	Off	-	24° / 25°

NOTE

- Error history lookup range: 50
- Error history information
- Item: date, time, mode (including Off), set temperature, incoming temperature, outgoing temperature, room temperature, Hot water operation / stop, Hot water set temperature, Hot water temperature, Outdoor unit On / Off, Error code
- Number of Display: Within 50
- Save criteria ▾
 - ▾ Error occurred, released
 - ON / OFF of outdoor unit operation

Password Initialization

It is the function to initialize (0000) when you forgot the password set in the remote controller.

- In the installer setting list, select the password initialization setting category, and press [OK] button to move to the detail screen.
- When you press "initialization" button, a popup screen appears, and when you press "check" button, password initialization starts, and the user password is changed to 0000.

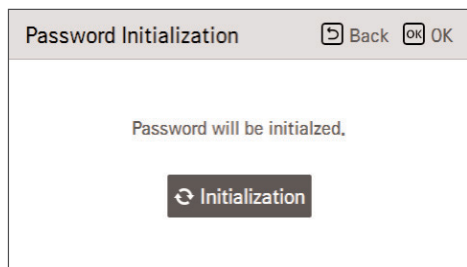
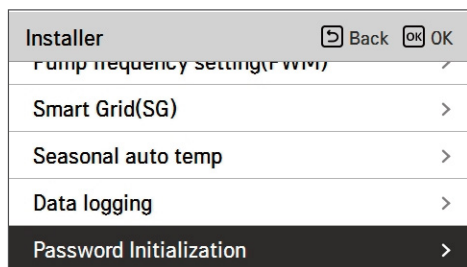

Power Supply Blockage (SG Ready)

The heat pump operated automatically by the power supply status signals from power supply companies. This function can respond to European countries' special tariff for heat pump using on a smart grid.

Power Supply Status	Operating Mode
	0:0 [Normal Operation] The heat pump works at maximum efficiency.
	1:0 [Switch-off command, Utility lock] Deactivates the heat pump to avoid peak load. The maximum blocking time depends on the system's thermal storage capacity, but amounts to at least 2 hours 3 times a day. (No frost protection)
	0:1 [Switch-on recommendation] The switch-on recommendation and set value storage tank temperature is increased, depending on the parameter "Mode SG" Mode SG : set temperature + α depending on the below parameter Step 0 (DHW +5°C) Step 1 (H/P+2°C, DHW +5°C) Step 2 (H/P+5°C, DHW +7°C)
	1:1 [Switch-on command] The command activates the compressor. Optionally, electrical booster heaters can be activated to utilize electricity surpluses

4 modes
depending on
power supply status

V. Checking Method for Key Components

1. Flow Switch	182
2. Water Pump	183
3. Electric Heater	184
4. Remote Controller	185
5. Compressor	186
6. Fan Motor	187

1. Flow Switch

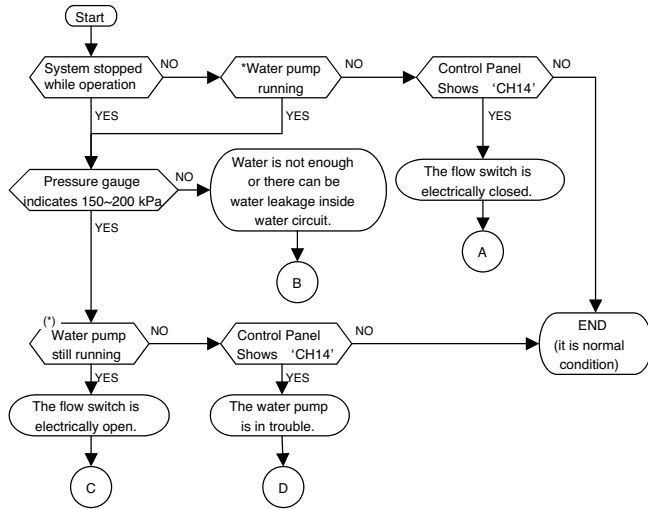

*: How to identify? - Touch the terminal box (black plastic box at the water pump) of water pump and feel if the water pump is vibrating. If no vibration, the water pump is not operating. Also, you can see 'Water Pump Operating' at control panel.

- (A)
 - Although there is not water flow inside water circuit, the flow switch detects as if water is flowing. It is due to electrically closed (or short) of flow switch or the contact of flow switch is mechanically stuck.
 - Contact official After Service Center and replace the flow switch.
 - Check the air vent. If there is air in the unit, it can display "CH14". Please remove the air by using the air vent.
- (B)
 - Check if water inside water circuit is fully charged. Pressure gauge at the unit should indicate 150~200 kPa.
 - Also, as the hand of the pressure gauge is not react so fast according to water charging, check the pressure gauge again.
 - Otherwise, there can be water leakage inside water circuit. Examine if water circuit is completely sealed.
- (C)
 - Although water is well flowing, the flow switch can not detect water flow. It is due to electrically open of flow switch or the contact of flow switch is mechanically broken.
 - Contact official After Service Center and replace the flow switch.
- (D)
 - Read 'Checking Key Components of Unit – Water Pump' carefully to get more detail information.
 - Contact official After Service Center and replace the water pump.
 - Also, check the water quality if there are particles that can yield locking at the shaft of the water pump.
 - Check the air vent. If there is air in the unit, it can display "CH14". Please remove the air by using the air vent.

2. Water Pump

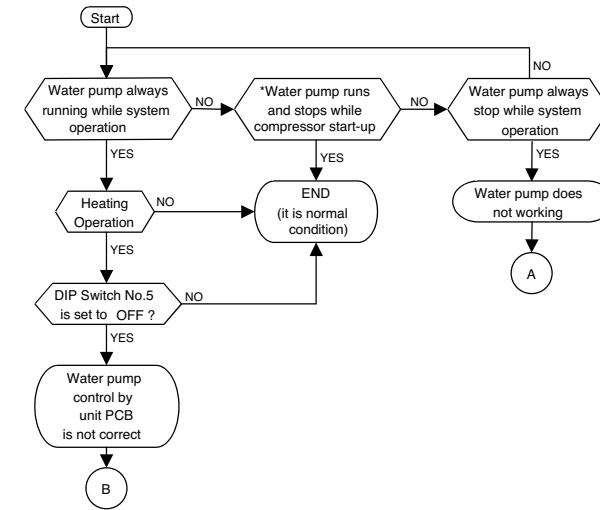

* : It is normal condition that water pump runs or stops during system operation (including compressor start-up) due to specific control logic.

- (A)
 - Water pump does not because of mechanical defects of water pump or wrong wiring at the water pump.
 - To correct mechanical defects, contact official After Service Center and replace the water pump.
- (B)
 - To correct wrong wiring, check if wires 'CN_MOTOR1' connector on the unit PCB and water pump terminal box (black plastic box at the water pump) are connected firmly. Also, check wires are electrically connected by measuring resistance of each wires (if electrically connected exactly, resistance should be 0 ohm).
 - Unit PCB can not make control signal or wrong wiring at the water pump.
 - To correct unit PCB's making control signal, first check the signal level. Use electric voltage meter and measure voltage at 'CN_MOTOR1' connector on the unit PCB. If measured value is not 220-240 V~ while 'Water Pump Operating' is displayed at control panel, the unit PCB is in trouble. In this case, contact official After Service Center and replace the unit PCB.
 - To correct wrong wiring, please refer (A).

3. Electric Heater

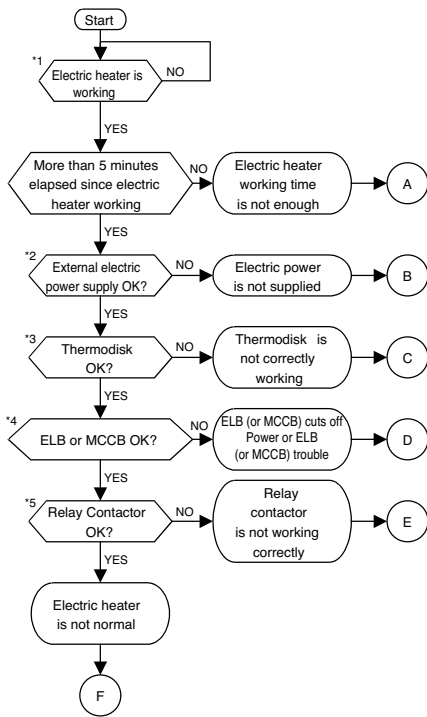

*1 : When electric heater is working, 'Electric Heater Operating' is displayed at control panel

*2 : For single-phase model : Measure electric voltage at port 3 (Live) and port 4 (Neutral) of Terminal Block 3 with voltage meter. The measured value should be 220-240 V~. To identify the location of Terminal Block 3, please refer circuit diagram of unit at 'Installation Manual' or backside of front cover of the unit.

*2 : For three-phase model : Measure electric voltage at two port of 3 (R), 4 (S), and 5 (T) of Terminal Block 3 with voltage meter. The measured value should be 220-240 V~ or 380-415 V~. To identify the location of Terminal Block 3, please refer circuit diagram of unit at 'Installation Manual' or backside of front cover of the unit.

*3 : For single-phase model : Find cover of thermodisk which is located beside air vent. Air vent is on the top of the electric heater tank. Uncover the cover by unscrewing bolts. Find two copper leads located both left and right side of the thermodisk core. Check resistance of both leads. The measured resistance should be 0 ohm. After then, check if voltage is transmitted to the thermodisk correctly. Measure electric voltage between one of the lead (Live) of the thermodisk and port 3 (Neutral) of ELB (A). The measured value should be 220-240 V~.

*3 : For three-phase model : Find cover of thermodisk which is located side of electric heater tank. Uncover the cover by unscrewing bolts. Find two copper leads located both left and right side of two thermodisk core. Check resistance of both leads of each thermodisks. The measured resistance should be 0 ohm.

⚠ While uncovering the cover of the thermodisk, be careful for electric shock.

*4 : For single-phase model : Resistance between port 1 and port 2 should be 0 ohm. Also, port 3 and port 4 should be 0 ohm, too. Finally, measure electric voltage at port 2 (Live) and port 4 (Neutral) with voltage meter. The measured value should be 220-240 V~.

*4 : For three-phase model : Resistance between port 1-to-port 2, port 3-to-port 4, and port 5-to-port 6 of MCCB (A) should be 0 ohm. Port number and location of MCCB (A) can be found circuit diagram of the unit(back side of front cover).

*5 : For single-phase model : At Relay Contactor (A), measure electric voltage at port 2 (Live) and port 6 (Neutral) with voltage meter. The measured value should be 220-240 V~. Also, at Relay Contactor (B), measure electric voltage at port 2 (Live) and port 6 (Neutral) with voltage meter. The measured value should be 220-240 V~.

*5 : For three-phase model : At Magnet Contact (C) or Magnet Contact (B), resistance between port L1-to-port T1, port L2-to-port T2, and port L3-to-port T3 should be 0 ohm.

- (A) • Wait for 5 minutes to heat water inside electric heater tank. If capacity of electric heater is 6kW, at least 2 centigrade will be increased.
- (B) • For single-phase model : Check if external electricity power supply is breakout. If not, check wiring between external electricity power supply and port 3 and port 4 of Terminal Block 3. You can identify the location of Terminal Block 3 at the circuit diagram of unit.
- (C) • For three-phase model : Check if external electricity power supply is breakout. If not, check wiring between external electricity power supply and port 3, port 4, and port 5 of Terminal Block 3. You can identify the location of Terminal Block 3 at the circuit diagram of unit.
- (D) • Thermodisk is mechanically defected. In this case, contact official After Service Center and replace the thermodisk.
- (E) • Check the insulation resistance of Electric Heater.
- (F) • If the insulation resistance has improper, remove the cause of the problem and then reset the ELB (or MCCB).
- (G) • Replace the ELB (or MCCB) when the insulation resistance is suitable.
- (H) • Relay contactor is mechanically defected. In this case, contact official After Service Center and replace the relay contactor.
- (I) • Heating coil of electric heater can be damaged or wiring inside the electric heater is problem. Before replacing the electric heater, in this case, contact official After Service Center and do diagnosis about electric heater and related parts including the capacity of external electric power source. If the reason of malfunction is clearly proved as the defect of the electric heater itself, then replace it with new one.

4. Remote Controller

To solve various troubles while using control panel, please read following FAQ (Frequently Asked Questions).
For your convenience, all questions are classified according to topics.

No	Topic	Question	Answer
1	Power button does not bright	System installation is finished. Also, all wirings including power connection is all right. But when the power button in front of the control panel is pushed, it does not bright.	<ul style="list-style-type: none"> • There can be a problem in wiring between PCB and control panel. Open control box and find 'CN_REMO' connector at the PCB. If the connector is empty or nothing is connected, please connect it with end of wire which is from control panel then restart the system. • Check if external controller is connected like thermostat. If thermostat is connected to the system and it is configured exactly, you can see 'Thermostat' text at the display of the control panel. It is normal condition that power button of control panel does not work when thermostat is installed.
2	Some texts are displayed automatically	Although nobody touched control panel, sometimes it displays specific texts and the system operates automatically.	<ul style="list-style-type: none"> • It is normal condition. Basically, two features can be operated without user's decision – one is system protective operation, the other is 'background water tank heating operation', which is heating inside the water tank while space heating is not used or the system is not working. System protective operation is, as letter says, for the purpose of securing the system from worse condition. Anti-freezing operation, for example, is one of the protective operation. It is essential to start protective operation to prevent potential malfunction and to keep possible accidents. On the other hand, background water tank heating operation is not protective operation but to supply warm water to end-user. The background water tank heating operation is only started when the water tank temperature is under the specific temperature.
3	Water tank heating or related features are not permitted	Setting water tank temperature is not permitted although the water tank is installed.	<ul style="list-style-type: none"> Following two conditions should be satisfied. • Check if 'Water tank enable/disable' is correctly displayed or not. To use water tank, end-user must push On/Off button focused on hot. • Also, check if DIP switch setting is correct or not. To identify the DIP switch setting, open the control box inside the unit. Unless 2nd and 3rd pin of DIP switch setting is 01(OFF-ON) or 10(ON-OFF), the water tank heating will not be configured.

5. Compressor

Check and ensure in following order when error related with the compressor or error related with power occurs during operation:

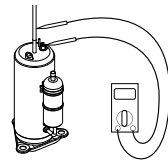
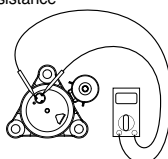
No.	Checking Item	Symptom	Countermeasure
1	Is how long power on during operation?	1) Power on for 12 hours or more	• Go to No.2.
		2) Power on for 12 hours or less	• Go to No.2 after applying power for designated time (12 hours).
2	Does failure appears again when starting operation? Method to measure insulation resistance  Method to measure coil resistance 	1) The compressor stops and same error appears again.	• Check IPM may fail.
		2) If output voltage of the inverter is stable.	• Check coil resistor and insulation resistor. If normal, restart the unit. If same symptom occurs, replace the compressor. • Insulation resistor: 2 MΩ or more • Coil resistor: Please refer to Page 68
		3) If output voltage of the inverter is unstable or it is 0 V. (When incapable of using a digital tester)	• Check the IPM. If the IPM is normal, replace the inverter board. • Check coil resistor and insulation resistor.

[Cautions when measuring voltage and current of inverter power circuit]

Measuring values may be different depending on measuring tools and measuring circuits since voltage, current in the power supply or output side of the inverter has no same waveform. Especially, output voltage changes when output voltage of the inverter has a pattern of pulse wave. In addition, measuring values appear largely different depending on measuring tools.

Note

- 1) If using a portable tester when checking the output voltage of the inverter is constant (when comparing relative voltage between lines), always use an analog tester. Especially exercise particular caution if the output frequency of the inverter is low, when using a movable tester, where change of measured voltage values is large between other lines, when virtually same values appear actually or where there is danger to determine that failure of the inverter occurred.
- 2) You can use rectification voltmeter (→) if using commercial frequency tester when measuring output values of the inverter (when measuring absolute values). Accurate measuring values cannot be obtained with a general portable tester (For analog and digital mode).

6. Fan Motor

Checking Item	Symptom	Countermeasure
(1) The fan motor does not operate. Does failure appears again when starting operation?	1) When power supply is abnormal	<ul style="list-style-type: none"> • Modify connection status in front of or at the rear of the breaker, or if the power terminal console is at frosting condition. • Modify the power supply voltage is beyond specified scope.
	2) For wrong wiring	<ul style="list-style-type: none"> • For following wiring. <ol style="list-style-type: none"> 1. Check connection status. 2. Check contact of the connector. 3. Check that parts are firmly secured by tightening screws. 4. Check connection of polarity. 5. Check short circuit and grounding.
(2) Vibration of the fan motor is large.	3) For failure of motor	• Measure winding resistance of the motor coils.
	4) For failure of circuit board	Replace the circuit board in following procedures if problems occur again when powering on and if there are no matters equivalent to items as specified in above 1) through 4). (Carefully check both connector and grounding wires when replacing the circuit board.) <ol style="list-style-type: none"> 1. Replace only fan control boards. If starting is done, it means that the fan control board has defect. 2. Replace both fan control board and the main board. If starting is done, it means that the main board has defect. 3. If problems continue to occur even after countermeasure of No.1 and No.2, it means that both boards has defect.

VI. Replacement

1. Replacement procedure for Compressor 190
2. Caution for Assembling Outdoor Panels after Test Run 192
3. Replacement Procedure for INV PCB 193

1. Replacement procedure for Compressor

1. Remove the sound proof covering the faulty compressor, and disconnect the power
2. Disconnect the brazing sections of suction pipe and discharge pipe by using brazing torch after the refrigerant has been pumped out or collected completely.
3. Remove three nuts at cushion rubber section to take out the faulty compressor outside the unit. <Figure 1>
4. Install the new compressor in the unit. (Be sure to insert the cushion rubbers before tightening the fixing nut of compressor.)
5. Remove the rubber caps put on the suction and discharge pipe of the new compressor to release the sealing nitrogen gas.
6. Braze the suction and discharge pipe with brazing torch to the compressor.
7. Conduct air tight test to check the piping system is free from leakage.
8. Connect power cable to the terminal board of compressor and cover the compressor with sound proof. <Figure 2>
9. Conduct vacuum.
10. After completion of vacuum, open the service valves. If recovery unit is used, charge refrigerant.

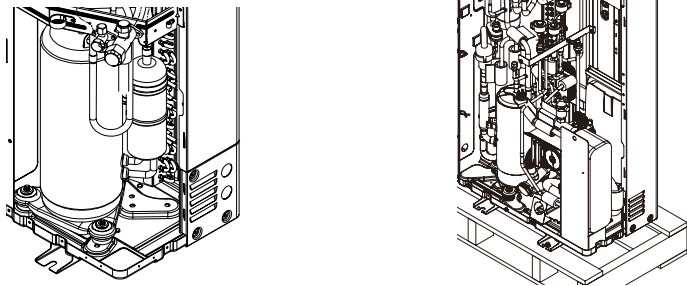

< Figure 1 >

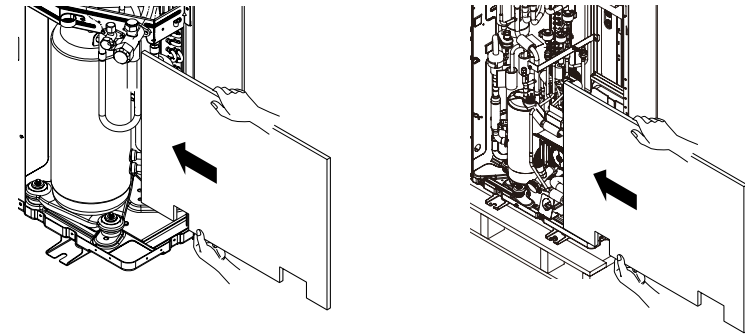

When inserting the sound proof, be sure to insert counter-clockwise.

< Figure 2 >

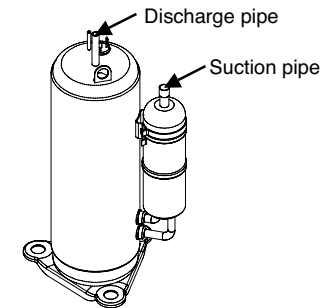

2. Caution for Assembling Outdoor Panels after Test Run

When assemble the outdoor panels after re-
placement, make sure that screws of top panel
are assembled as shown figure below.
If screws are not assembled, it allows rain come
into control box causing defect of unit.

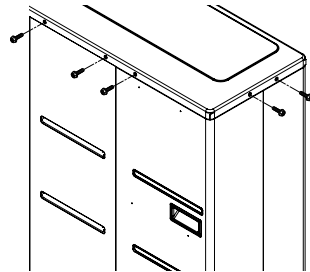
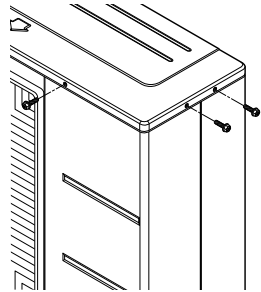

3. Replacement Procedure for INV PCB

1. Disassemble panel assembly by unscrewing screws. (Figure 1.)
2. Replace PCB assembly. (Figure 2.)
When assemble PCB assembly with control case, make sure that PCB case is inserted surely
in the slit of control case.
3. Assemble panel assembly and main PCB.

1Ø, 5kW / 7kW / 9kW

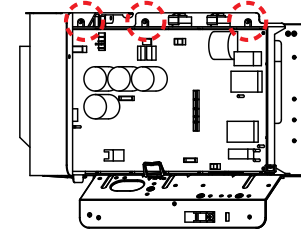

< Figure 1. >

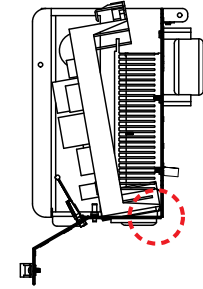

< Figure 2. >

1Ø, 12kW / 14kW / 16kW
3Ø, 12kW / 14kW / 16kW

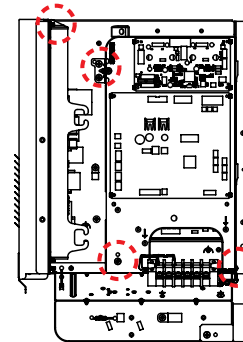

< Figure 1. >

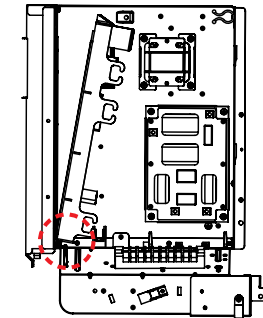

< Figure 2. >

! CAUTION

Be sure that PCB assembly is firmly assembled with control case.
Confirm that there is no gap between PCB case and control case.
If any gap is present, it will cause product malfunction.

VII. Test Run Check

1. Checking List of Initial Installation	196
2. Checklist	198
3. Test run flow chart	220

1. Checking list of initial installation

⚠ CAUTION

Turn off the power before changing wiring or handling product

No	Category	Item	Check Point
1	Electricity	Field wiring	<ul style="list-style-type: none"> All switches having contacts for different poles should be wired tightly according to regional or national legislation. Only qualified person can proceed wiring. Wiring and local-supplied electric parts should be complied with European and regional regulations. Wiring should be following the wiring diagram supplied with the product.
2		Protective devices	<ul style="list-style-type: none"> Install ELB (earth leakage breaker) with 30mA. ELB inside the control box of the unit should be turned on before starting operation.
3		Earth wiring	<ul style="list-style-type: none"> Earth should be connected. Do not earth to gas or city water pipe, metallic section of a building, surge absorber, etc.
4		Power supply	<ul style="list-style-type: none"> Use dedicated power line.
5		Terminal block wiring	<ul style="list-style-type: none"> Connections on the terminal block (inside the control box of the unit) should be tightened.
6	Water	Charged water pressure	<ul style="list-style-type: none"> After water charging, the pressure gage (in front of the unit) should indicate 2.0~2.5 bar. Do not exceed 3.0 bar.
7		Air purge	<ul style="list-style-type: none"> During water charging, air should be taken out through the hole of the air purge. If water does not splash out when the tip (at the top of the hole) is pressed, then air purging is not completed yet. If well purged, the water will splash out like fountain. Be careful when testing air purge. Splashed water may make your dress wet.
8		Shut-off valve	<ul style="list-style-type: none"> Two shut-off valves (located at the end of water inlet pipe and water outlet pipe of the unit) should be open.
9		By-pass valve	<ul style="list-style-type: none"> By-pass valve should be installed and adjusted to secure enough water flow rate. If water flow rate is low, flow switch error (CH14) can be occurred.

No	Category	Item	Check Point
10	Product Installation	Hang to the wall	<ul style="list-style-type: none"> As the unit is hung on the wall, vibration or noise can be heard if the unit is not fixed tightly. If the unit is not fixed tightly, it can fall down during operation.
11		Parts inspection	<ul style="list-style-type: none"> There should be no apparently damaged parts inside the unit.
12		Refrigerant leakage	<ul style="list-style-type: none"> Refrigerant leakage degrades the performance. If leakage found, contact qualified LG air conditioning installation person.
13		Drainage treatment	<ul style="list-style-type: none"> While cooling operation, condensed dew can drop down to the bottom of the unit. In this case, prepare drainage treatment (for example, vessel to contain condensed dew) to avoid water drop.

2. Checklist

• Make sure to check for OK on all items in the checklist below after installing the product.

Sort	Product	Contents	Check (OK / NO)
Installation	Split	Are pipings correctly connected?	
Refrigerant	Split	Was the standard airtight test run to check if there is any leakage from pipings and the product? (For R410A: 24-hour test with nitrogen pressure of 38kg)	
Refrigerant	Split	Is vacuum level kept at or below 0.5 torr or is there any change with vacuum for 1 hour after stopping the vacuum pump?	
Refrigerant	Split	Was additional amount of refrigerant correctly calculated based on the length of added piping and was the weight of refrigerant measured correctly with an electronic scale before injection?	
Refrigerant	Split	Is there any leakage after connecting the refrigerant pipings? Check gas detector and use soap bubbles to find any leakage.	
Installation	Split	Is the indoor unit installed in the building and installed and fixed according to the installation manual?	
Installation	Common	Is the outdoor unit installed and fixed firmly? Removal of wooden pallet and fixing with anchor	
Installation	Common	Is the outdoor unit installed at an appropriate location? (Consider air flow, noise and being under the eaves and etc.)	
Installation	Common	Is it possible to secure appropriate service area for the indoor unit? (More than 600mm to the front and 400mm to sides)	
Electric	Common	Is there a proper protective measure or earthing against lightning?	
Electric	Common	Is capacity of power lines and circuit breaker selected based on the atest catalogue of LG Electronics and is pull-in power for both indoor and outdoor units normal? (Power/control cables, earth leakage breaker) 3-phase 4-wire AC 380 V for general purpose / 3-phase 3-wire AC 380V for factories Check pull-in power for the indoor unit (1-phase 2-wire AC 220 V)	
Water pipe	Common	Is it proper to design the pipe diameter?	
Water pipe	Common	Is the quality of heat source water acceptable?	

Sort	Product	Contents	Check (OK / NO)
Water pipe	Common	Is there an appropriate measure against freezing and bursting plate heat exchanger in winter? (Use antifreeze solution or operate either pumps or auxiliary heater)	
Water pipe	Common	Is water filled in the system? Is water pipe pressure at the appropriate level?	
Water pipe	Common	Is it flushed?	
Water pipe	Common	Is the magnetic type strainer installed?	
Water pipe	Common	Is there any leakage from water pipe? (Check with visual inspection)	
Water pipe	Common	Is air vent valve installed and opened at the angled part of water pipe?	
Water pipe	Common	Are buffer tank and auxiliary pump installed? (Option)	

Items to check	Are pipings correctly connected? (Water piping, refrigerant piping)	Result
Purpose	Check piping connection	
Applicants	AWHP Split	

Check in/out flow of water pipe connections
Check connections of refrigerant piping and gas/liquid piping

Therma V - Split

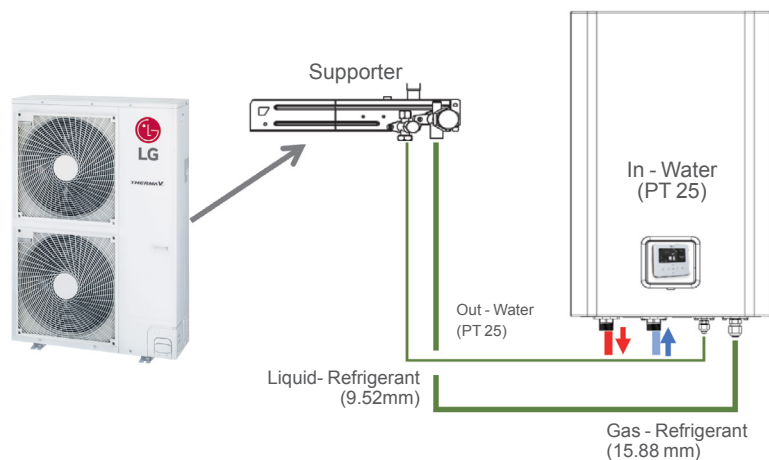

Therma V - Mono



Items to check	Was the standard airtight test run?	Result
Purpose	Check for leakage on pipings	
Applicants	AWHP Split	

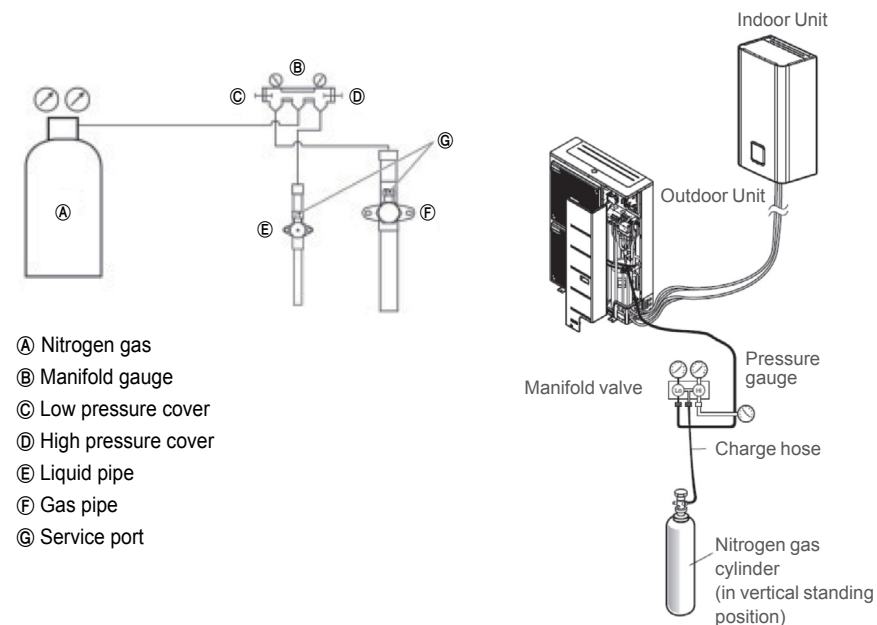

- Ⓐ Nitrogen gas
- Ⓑ Manifold gauge
- Ⓒ Low pressure cover
- Ⓓ High pressure cover
- Ⓔ Liquid pipe
- Ⓕ Gas pipe
- Ⓖ Service port

Be sure to use a manifold valve for leakage test.

If it is not available, use a stop valve for this purpose.

The "Hi" knob of the manifold valve must always be kept close.

- Pressurize the system to no more than 3.0 Mpa with dry nitrogen gas and close the cylinder valve when the gauge reading reaches 3.0 Mpa. Next, test for leaks with liquid soap. After the system is found to be free of leaks, relieve the nitrogen pressure by loosening the charge hose connector at the nitrogen cylinder. When the system pressure is reduced to normal, disconnect the hose from the cylinder.

Items to check	Is the vacuum level kept at or below 0.5 torr or is there any change with vacuum for 1 hour after stopping the vacuum pump?	Result
Purpose	Check for leakage on pipings	
Applicants	AWHP Split	

The operation time for evacuation varies with tubing length and capacity of the pump. The following table shows the time required for evacuation.

Required time for evacuation when 30 gal/h vacuum pump is used	
If tubing length is less than 10 m (33 ft)	If tubing length is longer than 10 m (33 ft)
30 min. or more	60 min. or more
0.5 torr or less	0.5 torr or less

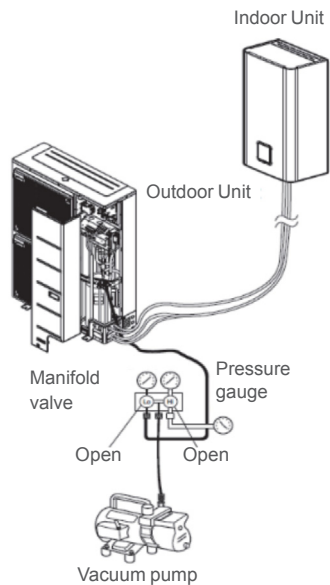

Finishing the job

1. With a service valve wrench, turn the valve stem of liquid side valve counter-clockwise to fully open the valve.
2. Turn the valve stem of gas side valve counter-clockwise to fully open the valve.
3. Loosen the charge hose connected to the gas side service port slightly to release the pressure, then remove the hose.
4. Replace the flare nut and its bonnet on the gas side service port and fasten the flare nut securely with an adjustable wrench. This process is very important to prevent leakage from the system.
5. Replace the valve caps at both gas and liquid side service valves and fasten them tight. This completes air purging with a vacuum pump. The air conditioner is now ready to test run.

Filling refrigerant (If refrigerant is filled additionally after repair or additional charging is needed)

1. Close both valves of manifold gauge, connect center hose (connection part of vacuum pump) to refrigerant tank to release air from hose from manifold gauge to charging cylinder (Open charging cylinder valve shortly to release air)
2. Open manifold gauge (Low compression: Blue) to fill gas first time and power on/operate the product and fill more gas.

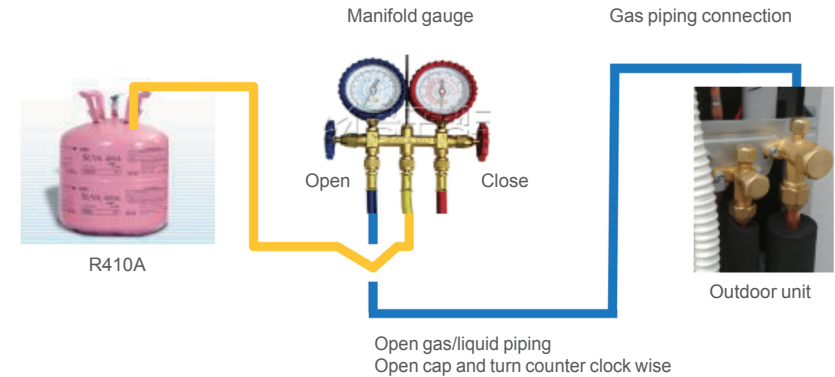

Items to check	Was additional amount of refrigerant correctly calculated based on the length of added piping and was the weight of refrigerant measured correctly with an electronic scale before injection?	Result
Purpose	Add refrigerant according to length of pipings	
Applicants	AWHP Split	

- Standard pipe length is 7.5 m. If the pipe length is longer than 7.5 m, additional charge of the refrigerant is required according to the table.
 - Example : If 16kW model is installed at a distance of 50 m, 1,700 g of refrigerant should be added according to following formula : $(50-7.5) \times 40 \text{ g} = 1,700 \text{ g}$
- Rated capacity of the product is based on standard length and maximum allowable length is based on the product reliability in the operation.
- Improper refrigerant charge may result in abnormal operation.

Capacity	Pipe Size (mm : inch) (Diameter : Ø)		Length A (m)		Elevation B (m)		* Additional Refrigerant (g/m)
	Gas	Liquid	Standard	Max.	Standard	Max.	
5 kW	15.88 (5/8")	9.52 (3/8")	7.5	50	0	30	40
7 kW							
9 kW							
12 kW							
14 kW							
16 kW							

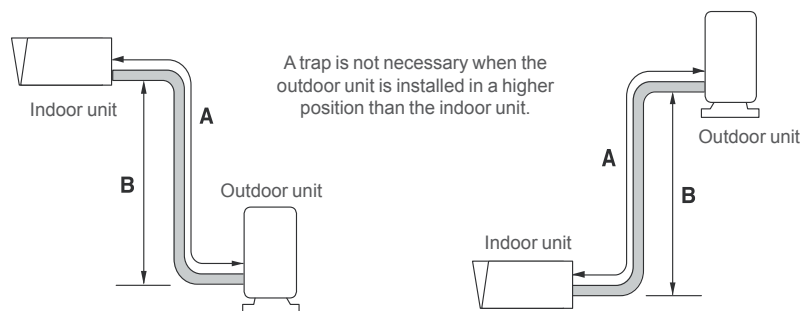

Items to check	Is the indoor unit installed in the building and installed and fixed according to the installation manual?	Result
Purpose	Installation of indoor unit	
Applicants	AWHP Split	

- The installation place should be free from outdoor weather conditions such as rain, snow, wind, frost, etc.
- Choose the place where is water-resistant or good drainage.
 - Service space should be secured.
 - No flammable materials around the indoor unit.
 - The place should be free of mouse from entering the indoor unit or attacking wires.
 - Do not place anything in front of the indoor unit to ensure air circulation around the indoor unit.
 - Do not locate anything under the indoor unit to be free from unexpected water out.
 - In case of water pressure increasing to 3 bar, water drainage should be treated when water is drained by safety valve.

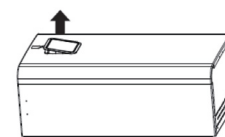

- Step 1. Disconnect the remote control case from the front panel and disconnect the remote control cable

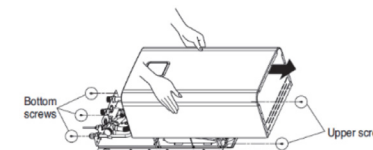

- Step 2. After releasing five screws, detach front cover from the indoor unit. While detaching the front cover, grab the left and right sides of the front cover. Then pull into upward direction.

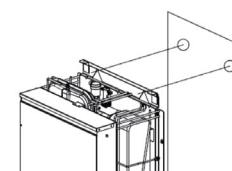

- Step 3. Attach "Installation Sheet" to the wall and mark the location of bolts. This sheet helps to find correct location to the bolts.

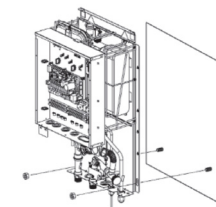

- Step 5. Hang the indoor unit at the supporting plate

- Step 4. Detach the Installation sheet. Screw bolts at the hole marks on the wall. When screwing bolts, use M8 ~ M11 anchor bolts to secure hanging the indoor unit.

Items to check	Is it possible to secure appropriate service area for the indoor unit and Backup heater?	Result
Purpose	Installation of indoor unit and back up heater	
Applicants	AWHP Split	

Ensure that the spaces indicated by arrows around bottom, side, and top side.

- Wider spaces are preferred for easy maintenance and piping.
- If minimum service space is not secured, air circulation can be a problem and internal parts of the indoor unit can be damaged by overheating.

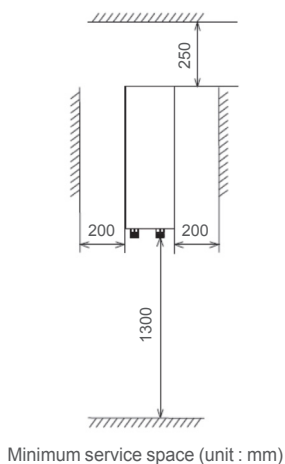
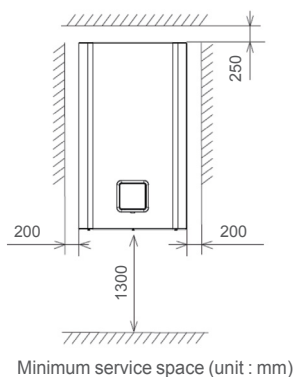

Items to check	Is the outdoor unit installed and fixed firmly? Removal of wooden pallet and fixing with anchor	Result
Purpose	Installation of indoor unit	
Applicants	Common	

Check the strength and level of the installation ground so that the unit will not cause any vibration or noise after installation.

- Fix the unit securely by means of the foundation bolts. (Prepare 4sets of M12 foundation bolts, nuts and washers each which are available on the market.)
- It is best to screw in the foundation bolts until their length are 20mm from the foundation surface.

Be sure to remove the Pallet (Wood Support) of the bottom side of the unit Base Pan before fixing the bolt.

It may cause the unstable state of the unit settlement, and may cause freezing of the heat exchanger resulting in abnormal operations.

- Be sure to remove the Pallet (Wood Support) of the bottom side of the unit before welding. Not removing Pallet (Wood Support) causes hazard of fire during welding.

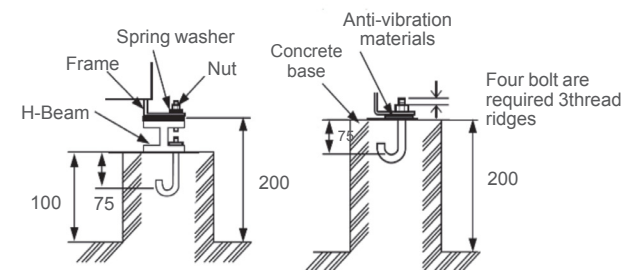
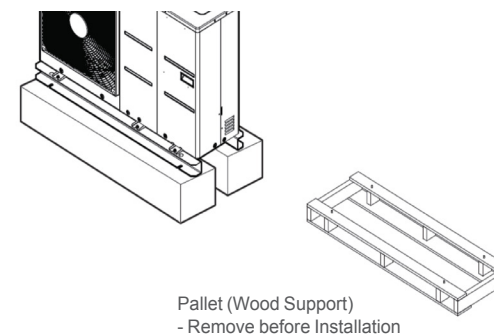

Items to check	Is the outdoor unit installed at an appropriate location? (Consider air flow, noise and being under the eaves and etc.)	Result
Purpose	Installation of outdoor unit	
Applicants	Common	

If an awning is built over the unit to prevent direct sunlight or rain exposure, make sure that heat radiation from the condenser is not restricted.

- Ensure that the spaces indicated by arrows around front, back and side of the unit.
- Do not place animals and plants in the path of the warm air.
- Take the air conditioner weight into account and select a place where noise and vibration are minimum.
- Select a place so that the warm air and noise from the air conditioner do not disturb neighbors.
- Place that can sufficiently endure the weight and vibration of the outdoor unit and where even installation is possible
- Place that has no direct influence of snow or rain
- Place with no danger of snowfall or icicle drop
- Place without weak floor or base such as decrepit part of the building or with a lot of snow accumulation

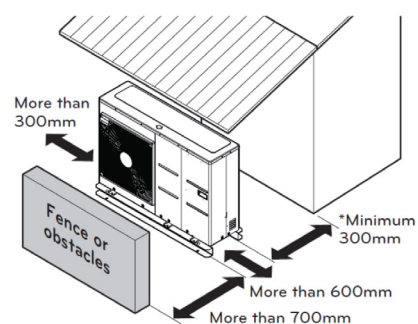

Items to check	Is there a proper protective measure or earthing against lightning?	Result
Purpose	Protection of product from lightning	
Applicants	Common	

When connecting earth cable, the diameter of cable should be bigger than 1.6mm² to secure safety.

The earth cable is connected to the terminal block where earth symbol is marked.



Be sure to correct the outdoor unit to earth. Do not connect earth line to any gas pipe, liquid pipe, lightning rod or telephone earth line. If earth is incomplete, it may cause an electric shock.

In order to ensure compliance with regulations on electrical equipment and cabling, follow the government regulations and instructions of power company.

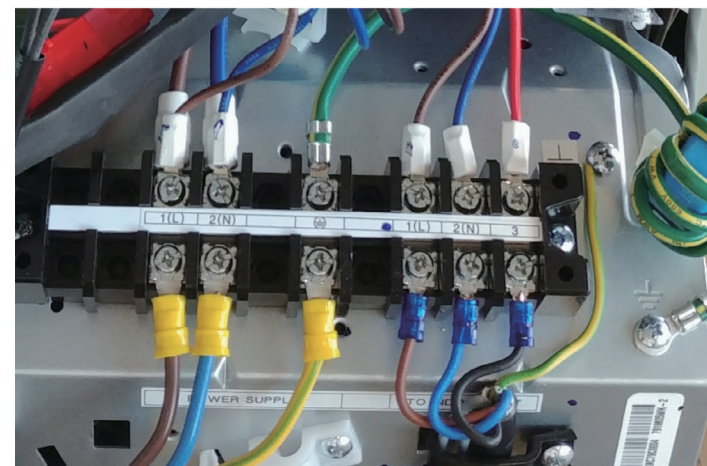

Items to check	Is it proper to design the pipe diameter?	Result
Purpose	Check water velocity and pressure drop	
Applicants	Common	

An easy method for selecting the piping diameter is as follows.

- Method by water Velocity (0.3 m/s ~ 3 m/s)
- Method by Pressure drop (40 kPa/m ~ 100 kPa/m)

1. Method by water Velocity (0.3 m/s ~ 3 m/s)

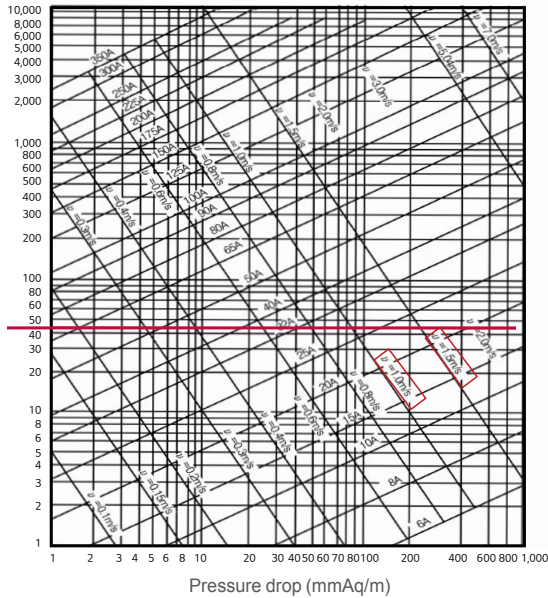

Ex) 16 kW Therma V
 ① Rated water flow rate : 46lpm ($\Delta 5^\circ\text{C}$)
 ② Velocity 1 ~ 1.5m/s

Select the pipe in the flow velocity range based on the y-axis flow line

Result : 25A or 32A (Pipe spec)

Remark)

If select 32A :
 1) High material cost
 2) Difficult to make layout

If select 20A :
 1) High Pressure drop by high velocity
 2) Noise

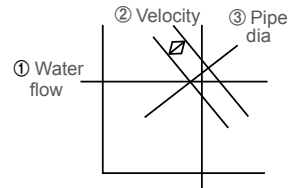

2. Method by Pressure drop (40kPa/m ~ 100kPa/m)

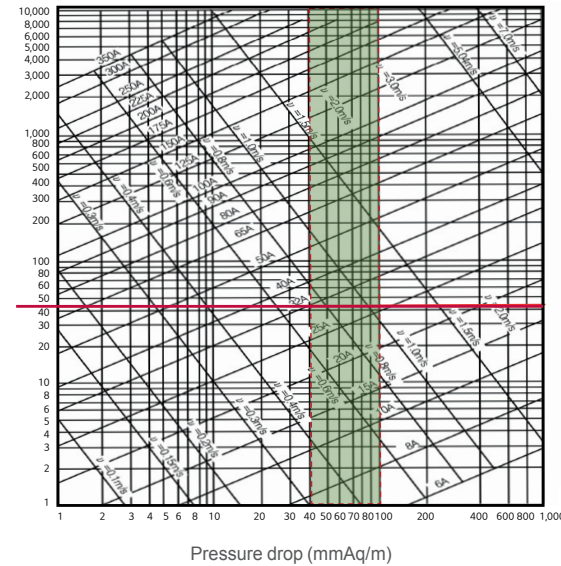

Ex) 16 kW Therma V
 ① Rated water flow rate : 46lpm ($\Delta 5^\circ\text{C}$)
 ② Pressure drop range : 40 ~ 100 kPa/m

Select the pipe in the pressure drop range based on the y-axis flow line

Considering flow velocity, select the pipe diameter

Result : 25A or 32A (Pipe spec)

Remark)

If select 32A :
 1) High material cost
 2) Difficult to make layout

If select 25A :
 1) Higher pressure drop than 32A
 2) Cost-effective

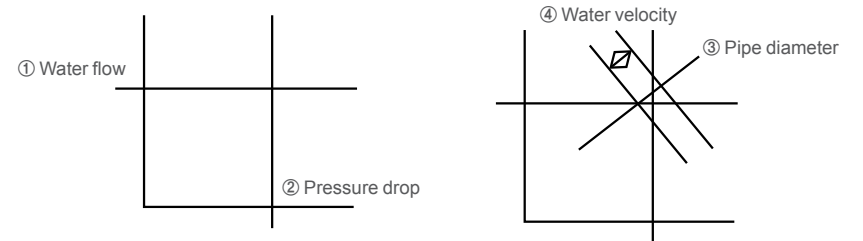

Items to check	Are buffer tank and auxiliary pump installed?	Result
Purpose	Secure flow and see if system is stabilized	
Applicants	Common	

Install the buffer tank with the following goals (Field scope).

1. For floor heating and if flow resistance is too high
2. For defrosting, oil retrieval operation and continuous heating
3. Preventing short cycle from load variation

Secondary pump needs to be installed if the buffer tank is to be installed (Field scope)

Generally a third party controller is installed to control the pump at the load side.

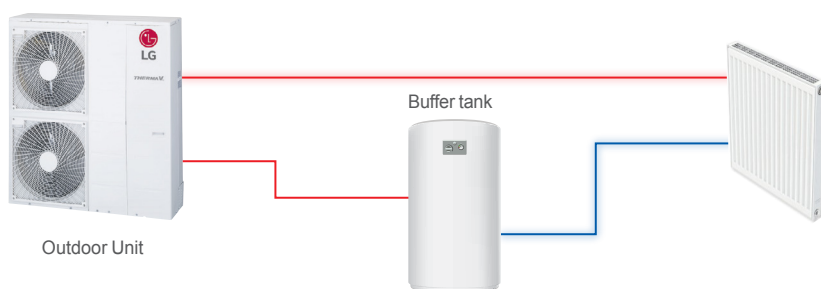
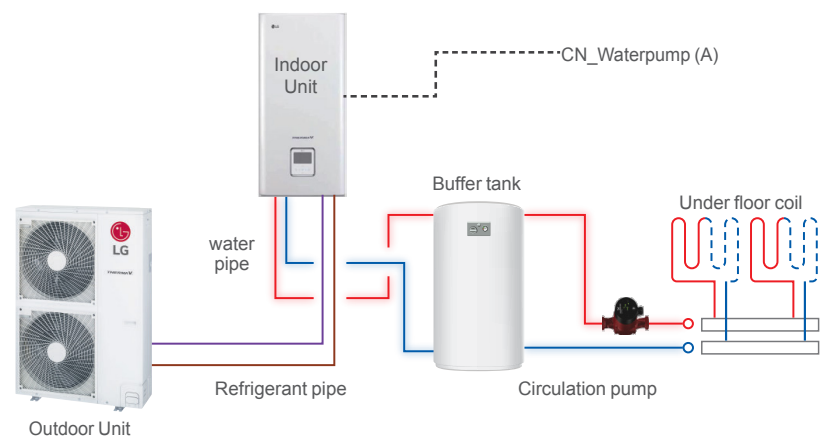

Items to check	Was flushing done?	Result
Purpose	Remove foreign objects and secure flow	
Applicants	Common	

There may be some foreign objects after new piping installation or equipment replacement.

Thus, connect the indoor unit only after clearing pipings so that there may be no foreign object in the piping.

Flushing can be done with the service valve and a separate pump and tap water.

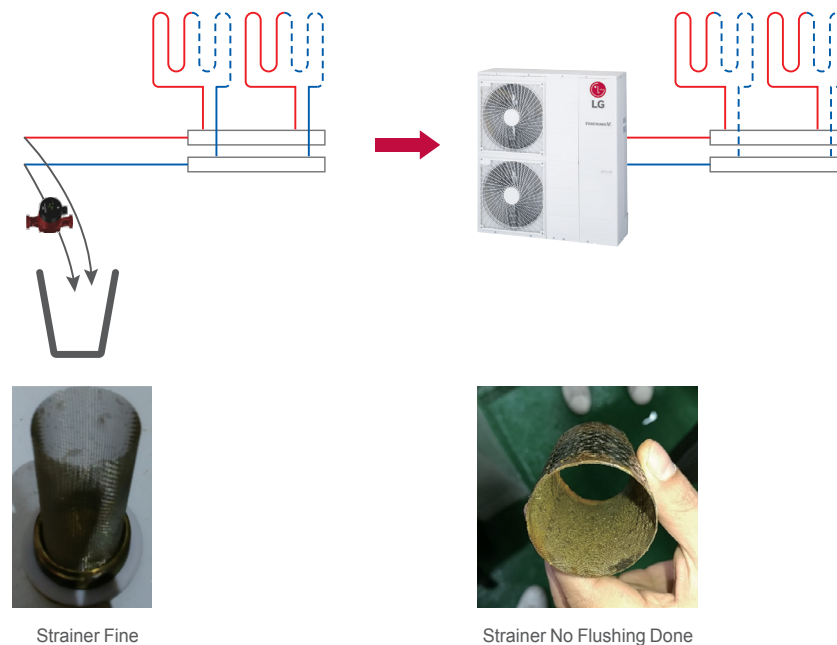

Items to check	Is quality of heat source water acceptable?	Result
Purpose	Protect product, secure flow	
Applicants	Common	

Water quality check should be implemented before completing the installation of system.

(Water range will be according s/UNE 122076:2004 IN and EN12499)

Detailed guide can be found in the table as below.

If the product is installed at existing hydraulic water loop, it is important to clean hydraulic pipes to remove sludge and scale.

- Installing sludge strainer in the water loop is very important to prevent performance degrade.
- Chemical treatment to prevent rust should be performed by installer.
- It is strongly recommended to install an additional filter on the heating water circuit. Especially to remove metallic particles from the heating piping, it is advised to use a magnetic or cyclone filter, which can remove small particles. Small particles may damage the unit and will NOT be removed by the standard filter of the heat pump system.

Use a simple measuring instrument or diagnose a sample to check water quality to verify the following. Also check pH, TDS(Total dissolved Solid), and water quality by applying formula such as LSI(Langelier saturation index).

Water contents	Concentration
pH	7.5 ~ 9.0
Conductivity	10 ~ 500 uS/cm
TDS (Total dissolved solids)	8 ~ 400 ppm
Alaklinity (HCO_3^-)	60 ~ 300 (mg/L)
Total hardness	4 ~ 8.5 °dH 71.4 ~ 151.7 (mg/L)
Iron (Fe)	≤ 0.2 (mg/L)
Sulphate (SO_4^{2-})	≤ 100 (mg/L)
Nitrite (NO_3^-)	≤ 100 (mg/L)
Free chlorine (Cl_2)	≤ 1 (mg/L)

Water contents	Concentration			
	ppm	STS316	STS304	
Chlorides (Cl^-)	pH7	15	3000	180
		40	500	50
		60	200	30
		80	125	20
	pH9	15	18000	700
		40	2600	250
		60	1000	170
		80	550	130

To caluate LSI, Need to measure pH, Temperature, Calcium Hardness (ppm), Alkalinity (ppm_ CaCO_3), Total Dissolved Solids (ppm) by using water quality test kits

[LSI]

Saturation Index	Remarks	Recommendation
-5	Severe Corrosion	Treatment Recommended
-3	Moderate Corrosion	Treatment Recommended
-2	Moderate Corrosion	Treatment may be Needed
-1	Moderate Corrosion	Treatment may be Needed
- 0.5	Mild Corrosion	Probably No treatment
0	None-Mild Corrosion	No Treatment
0.5	Near Balanced	Probably No treatment
1	Some Faint Coating	Treatment may be Needed
2	Mild Scale Coating	Treatment may be Needed
3	Moderate Scale Forming	Treatment Recommended
4	Severe Scale Forming	Treatment Recommended



Items to check	Is air vent valve installed and open at the angled part of water pipe??	Result
Purpose	Remove air from water pipe	
Applicants	Common	

Air vent valve is integrated in the product by default but additional ones may be needed if there are bent parts when pipings are installed.

Air Vent Valve is a device designed to remove air automatically from the hydronic heat pump system such as air remaining in the piping, dissolved air, and air that flowed in during installation.

- The air vent valve should be installed at every high point of the system.
- At the beginning and end of the curve
- At the water inlet/outlet pipe of the heat pump and heat exchanger
- At each branch piping connected to the main piping, when connecting multiple heat pumps

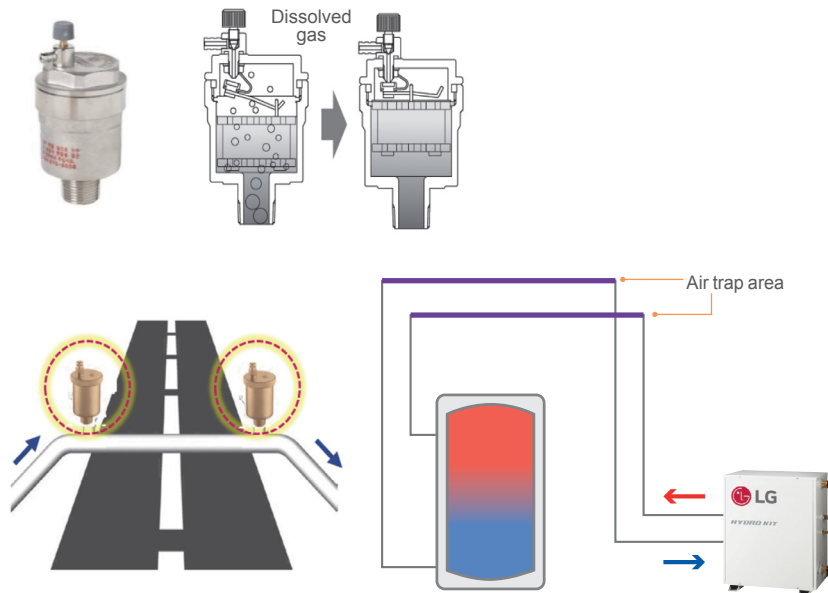

Items to check	Is there an appropriate measure to prevent freezing and bursting plate heat exchanger in winter? (Use antifreeze solution or operate either pumps or auxiliary heater)?	Result
Purpose	Subjects of preventing freezing	
Applicants	Common	

Antifreeze solution is needed to prevent freezing and bursting if outdoor temperature is too low or the product is to be out of use for extended period.

Adjust amount of antifreeze solution based on the site's conditions.

Check concentration of antifreeze solution and add more solution if concentration is too weak to maintain proper level of concentration.

Our own antifreeze logic is active by default but the protective logic may not work if the product fails, thus other physical measures need to be considered.

	Antifreezing mixing ratio (by volume)					
Freezing point	0 °C	-5 °C	-10 °C	-15 °C	-20 °C	-25 °C
Ethylene glycol	0	12.8	22	29	33.5	38
propylene glycol	0	15.5	26	33	39	44
Ethanol	0	14	24.8	32	37.3	42.2

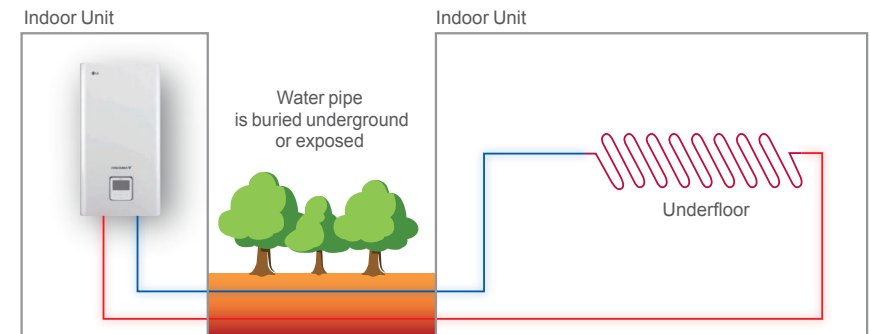

Items to check	Is water pipe pressure at appropriate level?	Result
Purpose	Secure flow, protect system	
Applicants	Common	

Check water pipe pressure when supplying tap water after first installation work.
Check pressure on the gauge either on the product or the gauge installed on site inside the piping.
Default pressure is 1bar and maximum is 3bar.
(Release water with relief valve inside the product if pressure is higher than 3bar)
Supply tap water until pressure is stabilized and maintained, and start supplying tap water when pressure reaches minimum of 0.3bar.

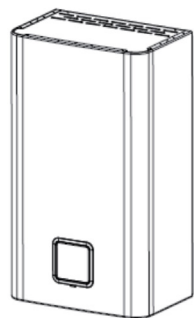
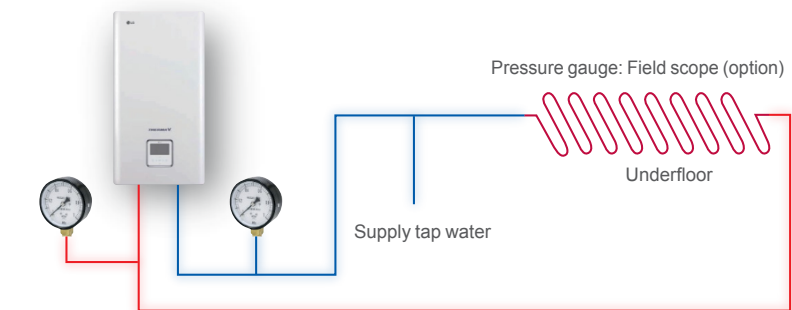

Pressure gauge inside product



Pressure gauge inside piping

Items to check	Was magnetic type strainer installed?	Result
Purpose	Secure flow, protect system	
Applicants	Common	

Especially to remove metallic particles from foul heating piping, it is recommended to use a magnetic or cyclone filter, which can remove small particles. Small particles may damage the unit and will NOT be removed by the standard filter of the heat pump system.

Magnetic strainer is separately available.
Install strainer on the water supply/inlet side for indoor unit.
Observe instructions of manufacturer of magnetic strainer.

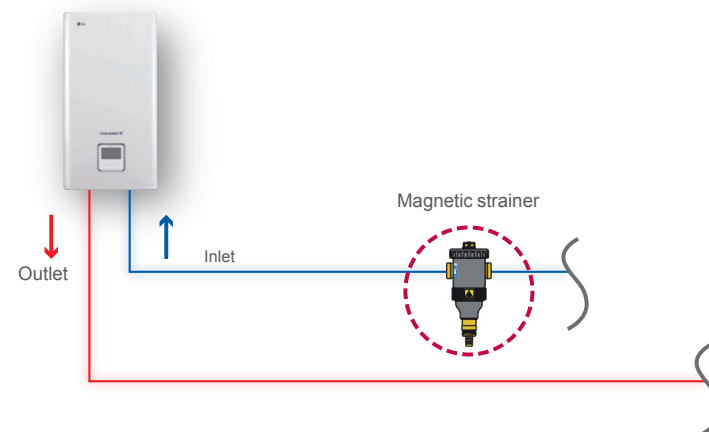

Magnetic filter

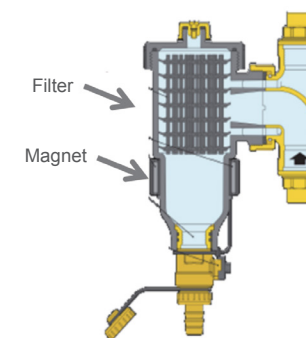

Trouble shooting guide

THERMA V™

Publisher LG Electronics Home Appliance & Air Solution Company, Air Solution Division
Issued date January 2019
Address LG Electronics Gasan A B/D, 56, Digital-ro 10-gil, Geumcheon-gu, Seoul, Korea
Web <http://partner.lge.com>

All rights are reserved by LG Electronics.

